Infrared (IR) Spectroscopy

3.1 Introduction

Infrared spectroscopy deals with the recording of the absorption of radiations in the infrared region of the electromagnetic spectrum. The position of a given infrared absorption is expressed in terms of wavelength in micron μ or more commonly in terms of wavenumber $\bar{\nu}$ (cm^{-1}) since it is directly proportional to energy. Note that wavenumbers are often called frequencies, although strictly it is incorrect. However, it is not a serious error as long as we keep in mind that $\bar{\nu} = \frac{1}{\lambda}$ and $\nu = \frac{c}{\lambda}$. The ordinary infrared region 2.5-15 μ ($4000\text{-}667 \text{ cm}^{-1}$) is of greatest practical use to organic chemists. The region 0.8-2.5 μ ($12,500\text{-}4000 \text{ cm}^{-1}$) is called the near infrared and the region 15-200 μ ($667\text{-}50 \text{ cm}^{-1}$) the far infrared. The absorption of infrared radiation by a molecule occurs due to quantized vibrational and rotational energy changes when it is subjected to infrared irradiation. Thus, IR spectra are often called *vibrational-rotational spectra*.

Unlike UV spectra which have relatively few absorption bands, IR spectra have a large number of absorption bands and therefore provide plenty of structural information about a molecule. Different bands observed in an IR spectrum correspond to various functional groups and bonds present in the molecule. Thus, IR spectroscopy is most widely used for the detection of functional groups and identification of organic compounds.

3.2 Instrumentation

Most IR spectrophotometers are double-beam instruments consisting of the following main parts:

- (i) Radiation source
- (ii) Sample and reference cells
- (iii) Attenuator and comb (photometer)
- (iv) Monochromator
- (v) Detector and amplifier
- (vi) Recorder

(i) Radiation Source

Infrared radiation is usually produced by electrically heating a Nernst filament (mainly composed of oxides of zirconium, thorium and cerium) or a globar (rod

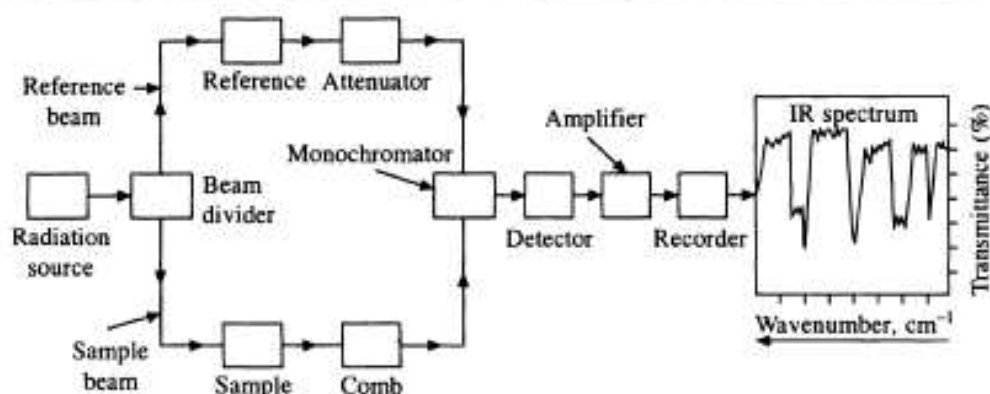

Fig. 3.1 Schematic diagram of a double-beam infrared spectrophotometer

of silicon carbide) to 1000–1800°C. The infrared radiation of successively increasing wavelength is used. The radiation from the source is divided into sample and reference beams of equal intensity by beam divider.

(ii) Sample and Reference Cells

Reference and sample beams pass through the reference cell and sample cell, respectively. Glass and quartz cannot be used as windows of cells and optical prisms, etc. because they absorb strongly in most of the IR region. Thus, alkali metal halides such as NaCl, NaBr, KCl and KBr are most commonly used as these are transparent to most of the IR region.

(iii) Attenuator and Comb (Photometer)

The reference beam passes through the attenuator and the sample beam through the comb. Then the two beams can be alternately reflected out of the optical system and to the entrance slit of the monochromator with the help of several mirrors. Thus, the photometer combines the reference and sample beams into a single beam of alternating segments. The comb allows balancing of the two beams.

(iv) Monochromator

The combined beam passes through the prism or grating of the monochromator which disperses the beam into various frequencies. Since the prism or grating rotates slowly, it sends individual frequency bands to the detector, thus allowing a scan of frequency bands. Gratings that give better resolutions than prisms consist of a series of parallel and straight thin lines on a smooth reflecting surface; the spacing between lines is of the order of few angstrom (\AA) depending on the desired wavelength range.

(v) Detector and Amplifier

The detector is a thermocouple which measures radiant energy by means of its heating effect that produces current. Due to difference in the intensity of the two beams falling on the detector, an alternating current starts flowing from the detector to the amplifier where it is amplified and relayed to the recorder.

(vi) Recorder

It records IR spectra as a plot of wavelengths λ or wavenumbers $\bar{\nu}$ of absorbed radiations against the intensity of absorption in terms of transmittance T or absorbance A . Presently we use the wavenumber unit as it is directly proportional to energy

$$T = \frac{I}{I_0}$$

$$T\% \text{ (percent transmittance)} = \frac{I}{I_0} \times 100$$

$$A = \log_{10} \frac{1}{T}$$

where I_0 is the intensity of the incident radiation and I the intensity of the radiation emerging from the sample.

IR absorption intensities are rarely described quantitatively, but they are described as *s* (strong), *m* (medium), *w* (weak) or *v* (variable). In IR spectroscopy, the magnitude of the molar extinction coefficient ϵ varies from near zero to around 2000. Here, ϵ is proportional to the square of the change in the dipole moment of the molecule that the particular absorption causes.

Wavenumbers are commonly calibrated by using one of the several peaks, e.g. 2850, 1603 or 906 cm^{-1} of a polystyrene film. It is common practice to record an IR spectrum along with polystyrene band (usually at 1603 cm^{-1}) on it.

At present, FT-IR (Fourier transform infrared) spectrophotometers have become common. The FT-IR instrument gives same information as a simple IR spectrophotometer but the former is much efficient, as it is quick, has high sensitivity and requires very small quantity of the sample.

3.3 Sample Handling

Infrared spectra of compounds may be recorded in the vapour phase, as pure liquids, in solution and in the solid state. The sample should be dry because water absorbs near $\sim 3710 \text{ cm}^{-1}$ and near $\sim 1630 \text{ cm}^{-1}$.

(i) In Vapour Phase

The vapour or gas is introduced into a special cell which is usually about 10 cm long and the walls of its both the ends are normally made of NaCl which is transparent to IR radiation. The vapour phase technique is limited because of the too low vapour pressure of most organic compounds to produce a useful absorption spectrum.

(ii) As a Liquid Film

A drop of neat liquid is placed between two flat plates of NaCl to give a thin film. Thick samples of neat liquids usually absorb too strongly to give satisfactory spectrum. This is the simplest of all sampling techniques.

(iii) In solution

Usually, a 1–5% solution of the compound is introduced into a special cell of

0.1–1 mm thickness and made of NaCl. In order to cancel out solvent absorptions, a compensating cell containing pure solvent is placed in the reference beam. The chosen solvent must not absorb in the region of interest. If the entire spectrum is of interest, then it should be recorded in different solvents in order to see all the bands clearly. For example, carbon tetrachloride and carbon disulphide may be used because the former shows little absorption above 1333 cm^{-1} and the latter below 1333 cm^{-1} has little absorption. The most commonly used solvents in IR spectroscopy are carbon disulphide, carbon tetrachloride and chloroform. The selected solvent should be inert to the sample. For example, carbon disulphide should not be used as solvent for primary or secondary amines.

(iv) In Solid State

(a) *As a mull or paste:* About 2–5 mg of a solid is finely ground in a agat mortar with one or two drops of the mulling agent. The mull is examined as a thin film between two flat plates of NaCl. The most commonly used mulling agent is nujol (a high-boiling petroleum oil). When C—H bands interfere with the spectrum, another mulling agent, hexachlorobutadiene, may be used.

(b) *As a pressed disc:* A solid about 0.5–1 mg is intimately mixed with about 100 mg of dry and powdered KBr. The mixture is pressed with special dies, under a pressure of 10,000–15,000 pounds per square inch, to give a transparent disc (pellet). The use of KBr eliminates the problem of bands due to the mulling agent and gives better spectra.

(c) *As deposited films:* The spectra of solids can also be recorded by depositing a glassy thin film of the compound on an alkali metal halide (NaCl or KBr) disc. The deposition takes place by putting a drop of the solution of the sample (in a volatile solvent) on the disc and then evaporating the solvent. Resins, plastics and waxy materials give satisfactory spectra by this technique.

In general, a dilute solution in a non-polar solvent gives the best, i.e. least distorted, IR spectrum because of far less intermolecular interactions. However, in the solid state or neat liquids, especially when polar groups capable of hydrogen bonding are present in the molecule, there are marked changes in spectral characteristics due to intermolecular interactions.

3.4 Theory (Origin) of Infrared Spectroscopy

IR absorption spectra originate from transitions in vibrational and rotational energy levels within a molecule. On absorption of IR radiation, vibrational and rotational energies of the molecule are increased. When a molecule absorbs IR radiation below 100 cm^{-1} , the absorbed radiation causes transitions in its rotational energy levels. Since these energy levels are quantized, a molecular rotational spectrum consists of discrete lines.

When a molecule absorbs IR radiation in the range $100\text{--}10,000\text{ cm}^{-1}$, the absorbed radiation causes transitions in its vibrational energy levels. These energy levels are also quantized, but vibrational spectra appear as bands rather than discrete lines. The energy differences between various rotational energy levels of a molecule are far less than that between its vibrational energy levels. Thus,

a single transition in vibrational energy levels is accompanied by a large number of transitions in rotational energy levels and so the vibrational spectra appear as vibrational-rotational bands instead of discrete lines. Organic chemists are mainly concerned with these vibrational-rotational bands, especially with those occurring in the region $4000\text{--}667\text{ cm}^{-1}$ ($2.5\text{--}15\ \mu$).

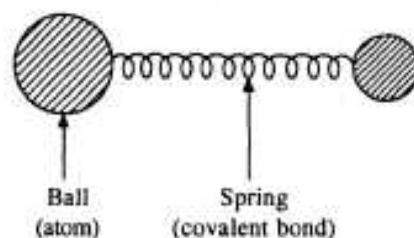

Various atoms in a molecule may be regarded as balls of different masses and the covalent bonds between them as weightless tiny springs holding such balls together. Atoms in a molecule are not still but they vibrate. The two types (modes) of fundamental molecular vibrations known are: (a) stretching and (b) bending vibrations (deformations).

(i) Stretching Vibrations

In stretching vibrations, the distance between two atoms increases or decreases, but the atoms remain in the same bond axis. Stretching vibrations are of two types:

(a) *Symmetrical stretching*. In this mode of vibration, the movement of atoms with respect to the common (or central) atom is simultaneously in the same direction along the same bond axis (Fig. 3.2(a)).

(b) *Asymmetrical stretching*. In this vibration, one atom approaches the common atom while the other departs from it (Fig. 3.2(b)).

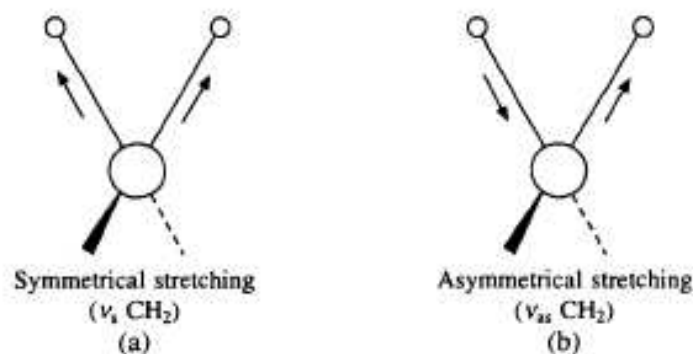

Fig. 3.2 Stretching vibrations of a CH_2 group (νCH_2)

(ii) Bending Vibrations (Deformations)

In such vibrations, the positions of the atoms change with respect to their original bond axes. Bending vibrations are of four types:

(a) *Scissoring*. In this mode of vibration, the movement of atoms is in the opposite direction with change in their bond axes as well as in the bond angle they form with the central atom (Fig. 3.3(a)).

(b) **Rocking.** In this vibration, the movement of atoms takes place in the same direction with change in their bond axes (Fig. 3.3(b)).

Scissoring and rocking are in-plane bendings.

(c) **Wagging.** In this vibration, two atoms simultaneously move above and below the plane with respect to the common atom (Fig. 3.3(c)).

(d) **Twisting.** In this mode of vibration, one of the atom moves up and the other moves down the plane with respect to the common atom (Fig. 3.3(d)).

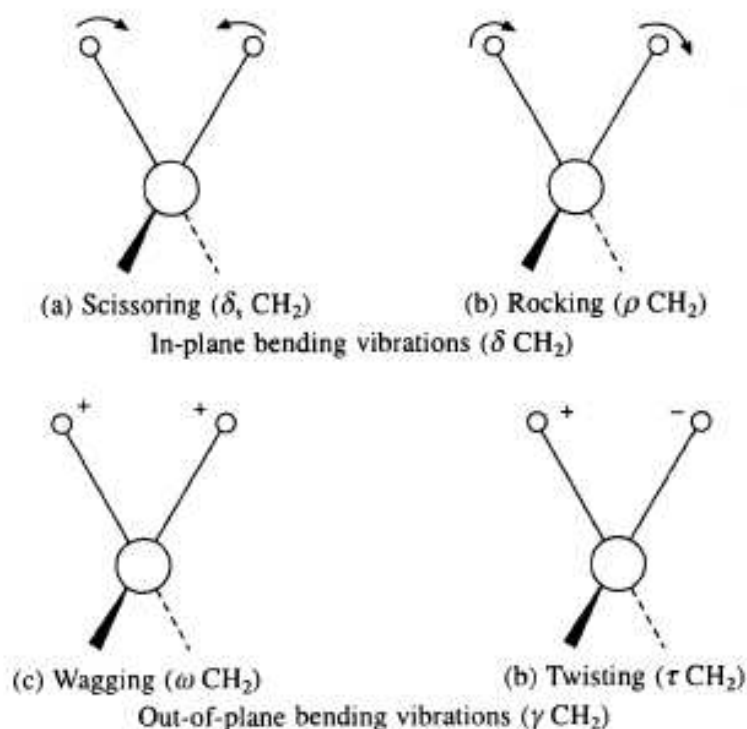
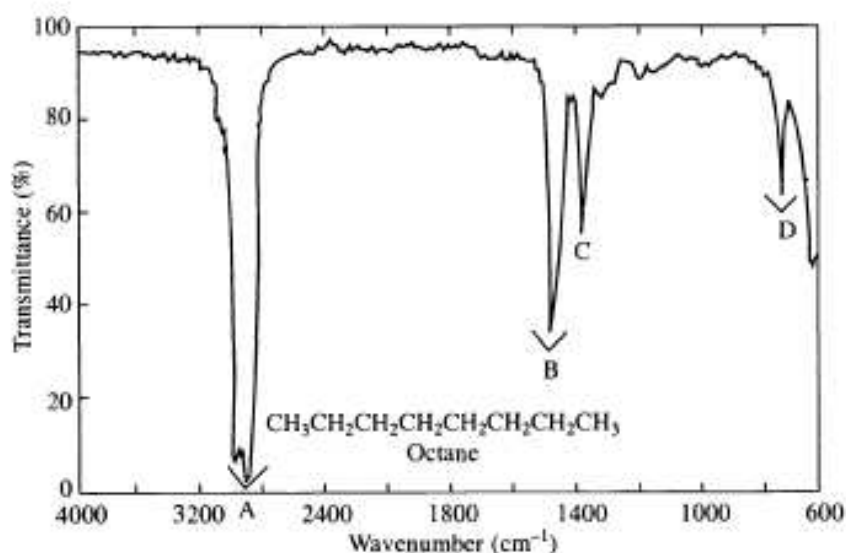

Fig. 3.3 Bending vibrations (deformations) of a CH_2 group (+ and - signs indicate movements perpendicular to the plane of the paper)

Infrared radiation is absorbed when the oscillating dipole moment, due to a molecular vibration, interacts with the oscillating electric field of the infrared beam. This interaction occurs and hence, an absorption band appears only when a molecular vibration produces a change in the dipole moment of the molecule. Otherwise, the vibration is said to be *infrared inactive* and it will show no absorption band in the infrared spectrum. Usually, larger the change in dipole moment, the higher is intensity of absorption. It is not necessary for a molecule to have a permanent dipole moment for IR absorption.

It may be noted that various stretching and bending vibrations of a bond have a definite and quantized frequency of their own. When infrared radiation of the same frequency is incident on the molecule, there is absorption of energy resulting in the increase of the amplitude of that particular absorption; now the molecule is in the excited state. Such an absorption gives rise to a peak in the IR spectrum. From the excited state, the molecule returns to the ground state by release of extra energy through rotational, collision and translational processes resulting in the increase of temperature of the sample under investigation.

We know that lesser energy is required to bend a spring than that required for stretching it. Analogously, bending vibrations of a bond require lesser energy than its stretching vibrations. Thus, the absorption bands resulting from bending vibrations appear at lower wavenumbers than those that result from stretching vibrations of the same bond. Stretching vibrations usually cause peaks of high intensity. A typical IR spectrum showing various modes of vibrations is given in Fig. 3.4.



A:	C—H stretching (ν C—H)	CH ₃	2960 cm ⁻¹ 2870 cm ⁻¹	ν_{as} CH ₃ ν_s CH ₃
		CH ₂	2925 cm ⁻¹ 2855 cm ⁻¹	ν_{as} CH ₂ ν_s CH ₂
B and C:	C—H bending (δ C—H)	CH ₃ and CH ₂	1470 cm ⁻¹ 1382 cm ⁻¹	δ_{as} CH ₃ and CH ₂ δ_s CH ₃
D:	CH ₂ rocking (ρ CH ₂)	CH ₂	725 cm ⁻¹	ρ CH ₂

Fig. 3.4 Infrared spectrum of octane, liquid film

3.5 Number of Fundamental Vibrations

The IR spectra of polyatomic molecules may exhibit more than one vibrational absorption bands. The number of these bands corresponds to the number of fundamental vibrations in the molecule which can be calculated from the degrees of freedom of the molecule. The degrees of freedom of a molecule are equal to the total degrees of freedom of its individual atoms. Each atom has three degrees of freedom corresponding to the three Cartesian coordinates (x , y and z) necessary to describe its position relative to other atoms in the molecule. Therefore, a molecule having n atoms will have $3n$ degrees of freedom. In case of a non-linear molecule, three of the degrees of freedom describe rotation and three describe translation. Thus, the remaining $(3n - 3 - 3) = 3n - 6$ degrees of freedom are its vibrational degrees of freedom or fundamental vibrations, because

$$\begin{aligned} \text{Total degrees of freedom } (3n) &= \text{Translational} + \text{Rotational} \\ &+ \text{Vibrational degrees of freedom} \end{aligned}$$

In case of a linear molecule, only two degrees of freedom describe rotation (because rotation about its axis of linearity does not change the positions of the atom) and three describe translation. Thus, the remaining $(3n - 2 - 3) = 3n - 5$ degrees of freedom are vibrational degrees of freedom or fundamental vibrations.

The number of vibrational degrees of freedom for the linear carbon dioxide molecule can be calculated as follows:

Number of atoms (n) = 3

Total degrees of freedom ($3n$) = $3 \times 3 = 9$

Rotational degrees of freedom = 2

Translational degrees of freedom = 3

Therefore, vibrational degrees of freedom = $9 - 2 - 3 = 4$

Since each vibrational degree of freedom corresponds to a fundamental vibration and each fundamental vibration corresponds to an absorption band, for carbon dioxide molecule there should be four theoretical fundamental bands.

Similarly, for a non-linear molecule ethane (C_2H_6), the vibrational degrees of freedom can be calculated as:

Number of atoms (n) = 8

Total degrees of freedom ($3n$) = $3 \times 8 = 24$

Rotational degrees of freedom = 3

Translational degrees of freedom = 3

Hence, vibrational degrees of freedom = $24 - 3 - 3 = 18$

Thus, theoretically there should be 18 absorption bands in the IR spectrum of ethane.

In case of benzene (C_6H_6), the number of vibrational degrees of freedom can be calculated as follows:

Number of atoms (n) = 12

Total degrees of freedom ($3n$) = $3 \times 12 = 36$

Rotational degrees of freedom = 3

Translational degrees of freedom = 3

Therefore, vibrational degrees of freedom = $36 - 3 - 3 = 30$

Thus, theoretically, there should be 30 fundamental vibrational bands in the IR spectrum of benzene.

It has been observed that in actual IR spectra, the theoretical number of fundamental bands are seldom obtained because there are certain factors which decrease, whereas certain factors increase the number of bands. The following factors decrease the theoretical number of fundamental bands:

- (i) The frequencies of fundamental vibrations which fall outside of the region $4000\text{--}667\text{ cm}^{-1}$.
- (ii) Fundamental bands which are so weak that they are not observed.
- (iii) Fundamental bands which are so close that they coalesce.
- (iv) The occurrence of a degenerate band from several absorptions of the same frequency in highly symmetrical molecules such as carbon dioxide.

- (v) Certain fundamental vibrational bands which do not appear in the infrared spectrum due to lack of the required change in dipole-moment of the molecule, e.g. in carbon dioxide molecule.

The carbon dioxide molecule is linear and has four fundamental vibrations $(3 \times 3) - 5 = 4$ (Fig. 3.5). Thus, four theoretical fundamental bands are expected but actually it shows only two. The symmetrical stretching vibration in carbon dioxide is IR inactive because it produces no change in the dipole moment of the molecule. The two bending vibrations are equivalent and absorb at the same wavenumber (667.3 cm^{-1}). Thus, the IR spectrum of carbon dioxide shows only two fundamental absorption bands, one at 2350 cm^{-1} due to asymmetrical stretching vibration, and the other at 667.3 cm^{-1} due to the two bending vibrations.

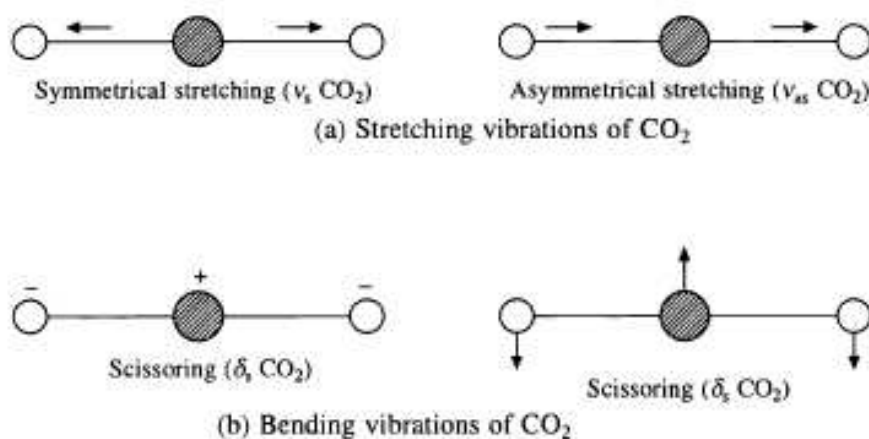

Fig. 3.5 Fundamental vibrations of the linear carbon dioxide molecule (+ and - signs indicate movements perpendicular to the plane of paper)

In a molecule having a centre of symmetry, the vibrations which are symmetrical about the centre of symmetry are IR inactive. For example, the symmetrical stretching vibrations of carbon dioxide and the symmetrical $\text{C}=\text{C}$ stretching vibrations of ethylene do not result in an absorption band in the IR spectra. It should be noted that ethylene shows bands for $\text{C}-\text{H}$ stretching vibrations. Similarly, symmetrical diatomic molecules such as H_2 , N_2 , O_2 and Cl_2 do not absorb IR radiation, but unsymmetrical diatomic molecules like carbon monoxide and iodine chloride ($\text{I}-\text{Cl}$) absorb IR radiation. Fundamental vibrations which are IR inactive may be Raman active and may give rise to observable bands in the Raman spectra.

The appearance of the following types of additional (non-fundamental) bands increases the number of bands as compared to that expected from the theoretical number of fundamental vibrations. All these bands have one-tenth to one-hundredth intensity of the fundamental bands.

(i) Overtone Bands

These may arise if a molecule is excited, e.g. from its first vibrational energy level to the third vibrational energy level; the energy required is almost twice of that required for the excitation to second vibrational energy level. In this way, if there are two fundamental bands at x and $y \text{ cm}^{-1}$, then the overtone bands can be

expected, e.g. at $2x$, $2y$, $3x$ and $3y$ cm^{-1} . The intensity of the overtone decreases as the order of the overtone increases, e.g. the second overtone ($3x$ or $3y$) is less intense than the first overtone ($2x$ or $2y$). Consequently, second and higher overtones are rarely observed, whereas first overtones are observed only for strong bands.

(ii) Combination Bands

If there are two fundamental bands at x and y cm^{-1} , then the combination bands can be expected, e.g. at $(x + y)$, $(x + 2y)$ and $(2x + y)$ cm^{-1} .

(iii) Difference Bands

If there are two fundamental bands at x and y cm^{-1} , then the difference bands can be expected, e.g. at $(x - y)$, $(x - 2y)$ and $(2x - y)$ cm^{-1} .

3.6 Calculation of Vibrational Frequencies

The stretching vibrations of two bonded atoms may be regarded as the vibration of two balls connected by a spring, a situation for which Hooke's law applies. Thus, an approximate value for the stretching vibrational frequency, i.e., the stretching absorption frequency of a bond, can be calculated by Hooke's law

$$\bar{\nu} = \frac{1}{2\pi c} \sqrt{\frac{f}{\mu}} \quad (3.1)$$

where $\mu = \frac{m_1 m_2}{m_1 + m_2}$ is the reduced mass, m_1 and m_2 are the masses (g) of the atoms linked to the particular bond, f the force constant of the bond in dynes/cm, c the velocity of light (2.998×10^{10} cm/sec) and $\bar{\nu}$ the stretching vibrational frequency of the bond in cm^{-1} (wavenumber).

The force constant of a bond is related to its bond strength. The value of force constant is approximately 5×10^5 dynes/cm for single bonds and approximately twice and thrice of this value for double and triple bonds, respectively.

The force constant is a characteristic property of a bond and like other physical constants, it is another physical constant. The frequencies of IR absorptions are commonly used to calculate the force constants of various bonds.

Applying Eq. (3.1) (Hooke's law), the frequency of the C—H stretching vibration can be calculated as follows:

The atomic mass of carbon is 12 and that of hydrogen is 1. Thus,

$$\bar{\nu} = \frac{1}{2\pi \times 2.998 \times 10^{10} \text{ cm sec}^{-1}} \times \sqrt{\frac{5 \times 10^5 \text{ dynes cm}^{-1} \left(\frac{12}{6.023} + \frac{1}{6.023} \right) \times 10^{-23} \text{ g}}{\left(\frac{12}{6.023} \times 10^{-23} \text{ g} \right) \left(\frac{1}{6.023} \times 10^{-23} \text{ g} \right)}}$$

Therefore, $\bar{\nu} = 3032 \text{ cm}^{-1}$.

Actually, C—H stretching vibrations of CH₃ and CH₂ groups are generally observed in the range 2850–3000 cm⁻¹.

The value of stretching vibrational frequency depends on the bond strength and the reduced mass. Obviously, the stretching vibrational frequency of a bond increases with an increase in the bond strength or decrease in the reduced mass of the bonded atoms. Thus, due to the greater bond strength (value of f) of C=C and C=O bonds, they are expected to absorb at higher stretching frequencies than that of C—C and C—O, respectively. Similarly, O—H stretching absorption appears at a higher frequency than that of C—C because of the lower value of reduced mass for O—H compared to that for C—C. For the same reason, we would predict O—H stretching vibration to be of higher frequency than O—D stretching vibration.

On the basis of reduced mass, we can expect that F—H bond should absorb at a lower stretching frequency than the C—H bond. Actually, F—H absorbs at a higher frequency (4138 cm⁻¹) than the C—H group (3040 cm⁻¹). This can be explained because there is an increase in the force constant when we proceed from left to right in the first two periods of the periodic table and this increase is more effective than the mass increase which tends to lower the absorption frequency. Thus, the relative contributions of bond strengths and atomic masses must be considered while applying the Hooke's law for predicting the vibrational frequencies of bond stretchings.

3.7 Factors Affecting Vibrational Frequencies

It should be noted that any factor which affects the force constant of a bond will affect its stretching frequency. There are various interrelated factors which shift the vibrational frequencies from their expected values. For this reason, the values of vibrational frequencies of the bonds calculated by the application of Hooke's law are not exactly equal to their observed values. The force constant of a bond changes with the electronic and steric effects of the other groups present in the molecule, and so the vibrational frequencies are shifted from their normal values. Also, frequency shifts may occur when the IR spectrum of the same compound is recorded in different states, viz. solid, liquid or vapour. Usually, a substance absorbs at higher frequency in the vapour state than that in the liquid or solid state. Following are some important factors which affect the vibrational frequencies of bonds.

(i) Coupled Vibrations

For an isolated C—H bond, only one stretching vibrational frequency is expected but a methylene group shows two absorptions corresponding to symmetrical and asymmetrical stretchings (Fig. 3.2(a) and (b)). This is because there is mechanical coupling or interaction between the C—H stretching vibrations in the CH₂ group. In all such cases, asymmetric stretching vibrations occur at higher frequencies or wavenumbers than the symmetric stretching vibrations. The C—H coupled vibrations of CH₂ groups are of different frequencies than that of CH₃ groups.

Coupling accounts for the two N—H stretching bands in the region 3077–

3497 cm^{-1} in the spectra of primary amines and primary amides. A strong vibrational coupling is present in carboxylic acid anhydrides in which symmetrical and asymmetrical stretching vibrations appear in the region $1720\text{--}1825\text{ cm}^{-1}$ and are separated by about 60 cm^{-1} . Here, two carbonyl groups are coupled through the oxygen. The interaction is very effective probably because of the partial double-bond character in the carbonyl oxygen bonds due to resonance which also keeps the system planar for effective coupling. The asymmetrical stretching band in acyclic anhydrides is more intense, whereas the symmetrical stretching band is more intense in cyclic anhydrides. This characteristic can be used for differentiating acyclic and cyclic anhydrides.

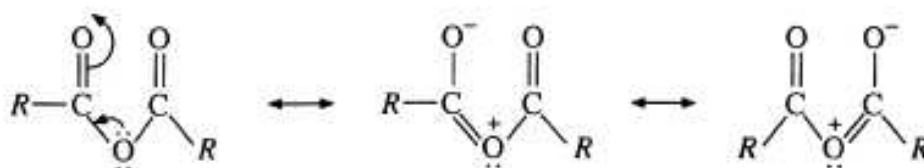

Resonating structures of an acid anhydride

Following are the requirements for effective coupling interaction:

- (i) Interaction is greatest when the individual absorption frequencies of the coupled groups are nearly the same.
- (ii) Strong coupling between stretching vibrations occur when the groups have a common atom between them.
- (iii) Coupling is negligible when groups are separated by one or more carbon atoms and the vibrations are mutually perpendicular.
- (iv) Coupling between bending vibrations can occur when there is a common bond, e.g. there is coupling between the bending vibrations of the adjacent C—H bonds in aromatic rings.
- (v) If the stretching bond forms one side of the changing angle, then coupling between stretching and bending vibrations can take place.

(ii) Fermi Resonance

We have discussed above the coupling between two fundamental vibrational modes. The coupling between fundamental vibrations and overtone or combination-tone vibrations of very similar frequency is known as *Fermi resonance* (after Enrico Fermi who first observed it in the case of CO_2). In Fermi resonance, a molecule transfers its energy from fundamental vibrational level to overtone or combination tone level and back. According to quantum mechanics, the resonance pushes the two levels apart and mixes their character, consequently each level has partly fundamental and partly overtone or combination tone character. Thus, Fermi resonance give rise to a pair of transitions of almost equal intensity, and so the resulting absorption bands usually appear as a doublet.

For example (as seen in Section 3.5), the symmetrical stretching vibration of CO_2 is IR inactive. For this stretching, Raman spectrum shows a strong band at 1337 cm^{-1} . The two bending vibrations (Fig. 3.4) are equivalent and absorb at the same frequency, of 667.3 cm^{-1} . The first overtone of this is $2 \times 667.3 = 1334.6\text{ cm}^{-1}$. Since it is very close to the frequency of the fundamental vibration

(symmetrical stretching), Fermi resonance occurs. Thus, there is mixing of 1337 cm^{-1} (fundamental) and 1334.6 cm^{-1} (overtone) levels in accordance with Fermi resonance to give two bands at 1285.5 cm^{-1} and at 1388.3 cm^{-1} with the intensity ratio 1:0.9, respectively. Some other examples of Fermi resonance are:

The absorption of aldehydic C—H appears as a doublet at ~ 2820 and $\sim 2720\text{ cm}^{-1}$ due to the interaction of C—H stretching vibration (fundamental) and the first overtone of C—H bending.

Appearance of a doublet in case of certain lactones and cycloketones can be explained with the help of Fermi resonance. Cyclopentanone shows carbonyl absorption at 1746 and 1750 cm^{-1} . This splitting is due to Fermi resonance with an overtone or combination band of an α -methylene group and the carbonyl band.

Fermi resonance is a common phenomenon in IR and Raman spectroscopy. It is observed only when the interacting groups are so located in the molecule that there is considerable mechanical coupling and that the fundamental and overtone or combination-tone vibrational levels are of the same symmetry species.

(iii) Hydrogen Bonding

Hydrogen bonding remarkably lowers the stretching frequencies of both the groups involved in it, and also changes the shape and intensity of the absorption bands. Usually, absorption bands become more intense and broad on hydrogen bonding. The stronger the hydrogen bond, lower is the O—H stretching frequency. Thus, the value of O—H stretching frequency is a test for hydrogen bonding as well as a measure of the strength of hydrogen bonds.

Non-hydrogen-bonded (free) O—H group of alcohols and phenols show sharp and strong absorption bands in the region $3590\text{--}3650\text{ cm}^{-1}$. Sharp, non-hydrogen-bonded O—H bands are observed only in the vapour phase, in very dilute solution, in non-polar solvents or when hydrogen bonding is prevented by steric hindrance. Pure samples and concentrated solutions of alcohols and phenols show broad O—H stretching bands in the region about $3200\text{--}3600\text{ cm}^{-1}$ due to intermolecular hydrogen bonding. The N—H stretching frequencies of amines are also affected by hydrogen bonding in the same way as that of the hydroxyl group but frequency shifts for amines are lesser than that for hydroxyl compounds. This is because nitrogen is less electronegative than oxygen and so the hydrogen bonding in amines is weaker than that in hydroxy compounds. For example, non-hydrogen-bonded primary amines exhibit two bands, one near 3400 cm^{-1} and the other near 3500 cm^{-1} due to symmetrical and asymmetrical N—H stretching modes, respectively. In pure amines, these bands respectively appear in the range $3250\text{--}3330\text{ cm}^{-1}$ and $3330\text{--}3400\text{ cm}^{-1}$ due to intermolecular hydrogen bonding.

In liquid or solid state, and in concentrated solutions, carboxylic acids exist as dimers due to strong intermolecular hydrogen bonding.

The strong hydrogen bonding between C=O and OH groups lowers their

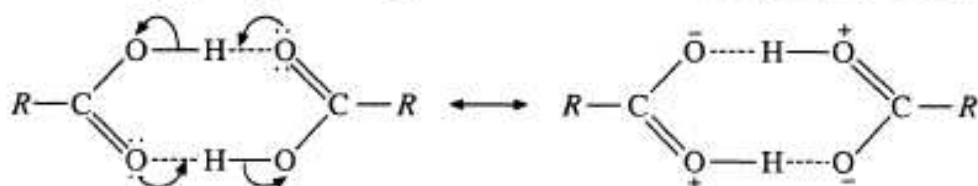

stretching frequency. Because of more polar O—H bond, carboxylic acids form stronger hydrogen bond than alcohols. Carboxylic acid dimers show very broad, intense O—H stretching absorption in the region $2500\text{--}3000\text{ cm}^{-1}$, whereas non-hydrogen-bonded carboxylic acids (monomers) show the O—H absorption near 3550 cm^{-1} . Hydrogen bonding weakens the C=O bond, i.e. its force constant is reduced, resulting in absorption at a lower frequency than the monomer. Thus, C=O stretching bands of monomers of saturated carboxylic acids appear at 1760 cm^{-1} , whereas that of dimers appear at about 1710 cm^{-1} .

In many cases, some O—H groups are hydrogen bonded and some are free. Hence, bands due to both may be observed.

Why does hydrogen bonding lower the absorption frequency?

Let us take the example of hydroxy compounds. On hydrogen bonding, the original O—H bond is lengthened (weakened) due to electrostatic attraction between the hydrogen atoms of one molecule and oxygen atom of the other, and thus the force constant of the O—H bond is reduced resulting in a decrease in its stretching frequency.

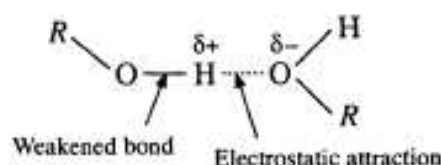

Further, the hydrogen bond may be regarded as a resonance hybrid of the following resonating structures, consequently the O—H bond is weakened and its stretching frequency is lowered.

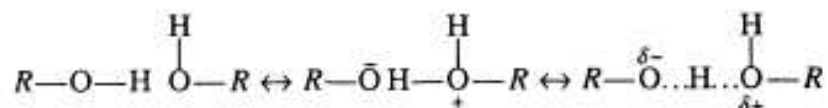

Distinction between inter- and intramolecular hydrogen bondings

In very dilute solutions (in non-polar solvents), intermolecular distances are too large to form intermolecular hydrogen bonds. On the other hand, in pure liquids, solids and concentrated solutions, the molecules are closer to form intermolecular hydrogen bond. Thus, intermolecular hydrogen bonding is concentration dependent. On dilution with non-polar solvents, intermolecular hydrogen bonds are broken. Hence, there is decrease in intensity or disappearance of the hydrogen-bonded O—H stretching band and increase in intensity or appearance of free O—H stretching absorption. Thus, in very dilute solutions (in non-polar solvents, concentration $< \sim 0.01\text{ M}$), the O—H stretching frequency is shifted to a higher frequency in case of intermolecular hydrogen bonding.

Intramolecular hydrogen bonding is within the same molecule, hence it is not affected by change in intermolecular distances. Thus, intramolecular hydrogen bonds are unaffected by dilution, and so the absorption band is also unaffected. Intramolecular hydrogen bonding (chelation) is very strong in enols and compounds

like methyl salicylate etc., due to resonance stabilization of the chelate ring. For example, in enols, the O—H group involved in chelation shows broad absorption band in the range $2500\text{--}3200\text{ cm}^{-1}$, whereas the C=O stretching band in enolic form occurs at 1630 cm^{-1} and that in the *keto* form at 1725 cm^{-1} . From the relative intensities of the two bands, it is possible to determine ratio of the *keto* and *enol* forms.

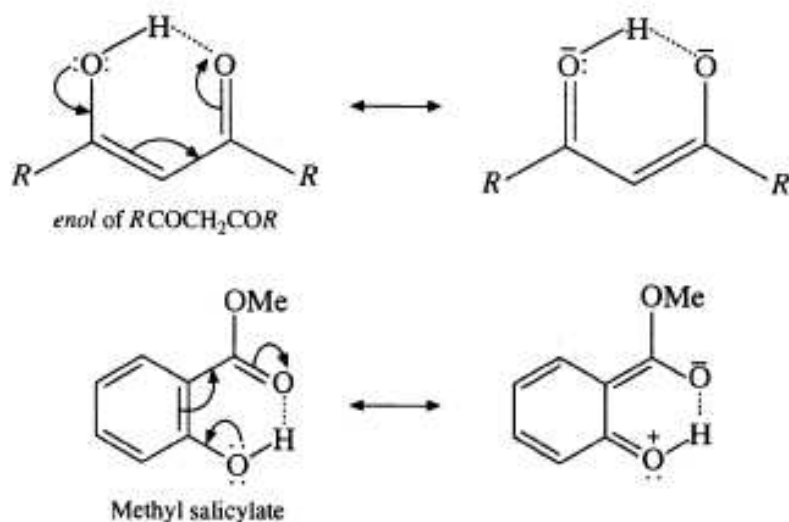

Due to interactions of π electrons of Lewis bases (such as alkenes and benzene) with acidic hydrogen, lengthening and hence weakening of O—H bonds has also been observed. For example, the O—H stretching frequency of phenols is lowered by $40\text{--}100\text{ cm}^{-1}$ when the spectrum is recorded in benzene solution as compared to that recorded in CCl_4 solution.

(iv) Inductive and Mesomeric (Resonance) Effects

Absorption frequencies of a particular group are affected by electronic effects, especially inductive and mesomeric (resonance) effects of the nearby groups. These effects are generally interrelated and their individual contribution can only be estimated approximately. Strength (force constants) of a particular bond is changed by these effects and hence its stretching frequency is also changed with respect to the normal values. Both of these effects may operate in the same direction or opposite to each other where one dominates the other.

A carbonyl compound may be considered as a resonance hybrid of the following structures:

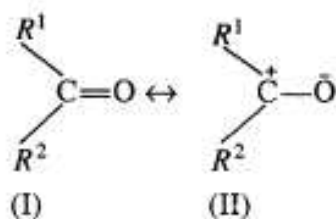

The stretching frequency of a carbonyl group decreases with increasing number of alkyl groups attached to it. This is due to $+I$ effect of alkyl groups which

favours structure (II) and lengthens (weakens) the carbon-oxygen double bond, and hence its force constant is decreased resulting in the lowering of the $\text{C}=\text{O}$ stretching frequency. For example, HCHO , CH_3CHO and CH_3COCH_3 show $\nu_{\text{C}=\text{O}}$ absorption at 1750, 1730 and 1720 cm^{-1} , respectively. It should be noted why aldehydes absorb at higher frequency than ketones. Similarly, when a group with $-I$ effect is attached to a $\text{C}=\text{O}$ group, it favours structure (I) and its stretching frequency is increased due to increase in the bond order (force constant) of the carbon-oxygen double bond. For example, CH_3COCH_3 , CH_3COCF_3 and CF_3COCF_3 show $\nu_{\text{C}=\text{O}}$ bands at 1720, 1769 and 1801 cm^{-1} , respectively.

Amides show $\nu_{\text{C}=\text{O}}$ band at a lower frequency than that of esters. Due to lesser electronegativity of nitrogen than oxygen, its lone pair of electrons are more readily involved in resonance than that of oxygen. Thus, the carbon-oxygen double bond character is more reduced by resonance in amides than that in esters resulting in a much lower $\nu_{\text{C}=\text{O}}$ frequency of amides than that of esters. For example, benzamide shows $\nu_{\text{C}=\text{O}}$ band at 1663 cm^{-1} and methyl benzoate at 1735 cm^{-1} .

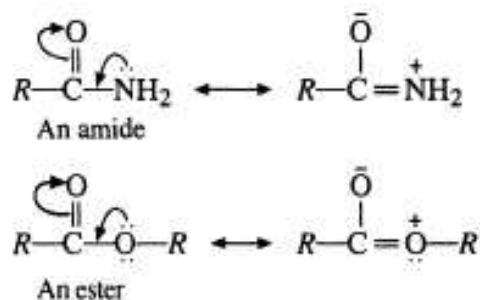

Conjugation of a carbonyl group with an olefinic double bond or an aromatic ring lowers the stretching frequency of the $\text{C}=\text{O}$ groups by about 30 cm^{-1} . This is because the double bond character of the $\text{C}=\text{O}$ group is reduced by mesomeric effect.

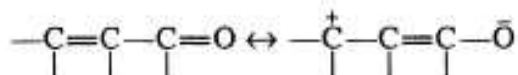

For example, the stretching frequency of $\text{C}=\text{O}$ group in acetone is 1720 cm^{-1} , whereas acetophenone shows $\nu_{\text{C}=\text{O}}$ band at 1697 cm^{-1} due to its conjugation with the aromatic ring. In this case, $-I$ effect of the sp^2 -carbon of the ring is dominated by the $+M$ effect of the ring.

3.8 Characteristic Absorptions in Common Classes of Compounds

Various groups present in various classes of organic compounds are responsible for IR absorptions in different frequency regions. Most of these group absorptions are characteristic of a particular class of compounds. These characteristic group frequencies (given in Table 3.1) along with effects of structural environments on them are discussed as follows.

(i) Alkanes and Alkane Residues

The most characteristic absorptions in alkanes and alkane residues ($-\text{CH}_3$,

—CH₂— and >CH—) are C—H stretching and bending absorptions occurring in the regions 2840–3000 cm⁻¹ and 1340–1485 cm⁻¹, respectively (Table 3.1). The C—H stretching commonly appears as two bands—one for symmetrical and the other for asymmetrical stretching. Due to their inert nature, the absorption positions of alkane residues are hardly affected by their chemical environment (Fig. 3.4).

Absorptions due to ν_{C-C} vibrations occur in the range 800–1200 cm⁻¹ and are generally weak, hence practically not useful for identification. This low frequency range compared to C—H vibrations is due to differences in atomic masses of C—H and C—C groups. Since most organic compounds possess alkane residues, their absorption bands are of little value in structure determination. Of course, the absence of an absorption due to an alkane residue is an evidence for the absence of such a part structure in the molecules. When alkane residues are attached to a carbonyl group, a heteroatom (e.g. N or O) or an aromatic ring, their stretching bands appear below 3000 cm⁻¹ (Table 3.1).

(ii) Cycloalkanes (Cycloparaffins)

The C—H stretching frequencies in cycloalkanes increase with increasing ring strain. However, in strainless rings such as cyclohexane they are almost same as in alkanes (Table 3.1). For example, CH₂ and CH groups in monoalkyl cyclopropanes absorb in the region 2985–3060 cm⁻¹, whereas that in cyclohexanes around 2850–2930 cm⁻¹. The frequency of CH₂ absorbs at 1468 cm⁻¹, whereas that of cyclopropane and cyclohexane at 1442 cm⁻¹ and 1452 cm⁻¹, respectively.

(iii) Alkenes

Unconjugated C=C bonds have stretching frequency in the region 1620–1680 cm⁻¹ (Table 3.1). More substituted double bonds absorb at higher frequencies compared to less substituted C=C bonds. The larger the change in dipole moment during the vibration, stronger is the absorption. Thus, C=C stretching absorption is very weak when the double bond is more or less symmetrically substituted. For the same reason, the intensity of $\nu_{C=C}$ bands of *trans* alkenes is lesser than that of *cis* alkenes but the absorption frequencies of these bands are higher for *trans* alkenes than that for *cis* alkenes (Table 3.1).

Conjugation of the C=C double bond with a double bond or an aromatic ring decreases the frequency of the C=C bond. The IR spectrum of an asymmetrical conjugated diene like 1,3-pentadiene shows two stretching bands, one near 1600 cm⁻¹ and the other near 1650 cm⁻¹. The asymmetrical alkene like 1,3-butadiene shows only one band near 1600 cm⁻¹ due to asymmetrical stretching. The symmetrical stretching of such molecules is inactive in the infrared. Cumulative double bonds (C=C=C) show strong absorption near 1900–2000 cm⁻¹.

Olefinic =C—H stretching appears in the region 3000–3100 cm⁻¹. Terminal double bonds absorb more strongly than internal double bonds. The most characteristic vibrational modes of olefins are the out-of-plane bending vibrations which appear in the region 650–1000 cm⁻¹ (Table 3.1). These are the strongest bands in the spectra of olefins. A pair of intense bands in this region (one near 910 cm⁻¹ and the other near 990 cm⁻¹) shows the presence of vinyl (R—CH=CH₂)

double bond, whereas only one band near 890 cm^{-1} shows the presence of vinylidene ($R_2C=CH_2$) type double bond. Bands due to out-of-plane bending of olefinic C—H of *trans* alkenes are relatively stronger and appear at higher frequencies than that of *cis* alkenes.

(iv) Alkynes

Alkynes show a $C\equiv C$ stretching band with variable intensity in the region $2100\text{--}2260\text{ cm}^{-1}$. Due to symmetry, weak or no $C\equiv C$ stretching band is observed in the spectra of acetylene and symmetrically substituted alkynes. Because of symmetry reasons, a terminal $C\equiv C$ gives stronger stretching band than an internal $C\equiv C$ (pseudosymmetry). The $\equiv C-H$ stretching band of alkynes occurs around 3300 cm^{-1} . This band is stronger and narrower than the hydrogen-bonded O—H or N—H stretching bands occurring in the same region, hence can be distinguished from them. The absorption due to $\equiv C-H$ bending of alkynes appears as a strong and broad band in the region $610\text{--}645\text{ cm}^{-1}$ (Table 3.1).

(v) Halogen Compounds

As the electronegativity of halogen increases, symmetrical and asymmetrical stretching frequencies of C—H bond in CH_3-X decrease, whereas its bending vibrations are shifted to higher frequency. The bending vibrations of the C—H bond in CH_3-X appear in the region $1250\text{--}1500\text{ cm}^{-1}$, in CH_3F being at the highest frequency and in CH_3I at the lowest. The bending vibrations of the C—X bond in halogen compounds are strong and appear in the regions: C—F, $1000\text{--}1400$; C—Cl, $600\text{--}800$; C—Br, $500\text{--}750$ and C—I, $\sim 500\text{ cm}^{-1}$, i.e. the frequency of bending absorption decreases with decreasing electronegativity of the halogen (Table 3.1).

(vi) Aromatic Hydrocarbons

Aromatic C—H stretching bands occur in the region $3000\text{--}3100\text{ cm}^{-1}$. Out-of-plane bending bands of the ring C—H appear in the region $675\text{--}900\text{ cm}^{-1}$. In-plane C—H bending bands appear in the region $1000\text{--}1300\text{ cm}^{-1}$. In aromatic compounds, the most characteristic medium bands due to C—C stretching appear around 1600 , 1580 (when ring is further conjugated), 1500 and 1450 cm^{-1} . The absence of these bands indicates that the compound is not aromatic. Monosubstituted benzenes show characteristic, strong bands in the regions $690\text{--}710$ and $730\text{--}770\text{ cm}^{-1}$. *Ortho*-disubstituted benzenes show a strong band in the region $735\text{--}770\text{ cm}^{-1}$, but no band in the region $690\text{--}710\text{ cm}^{-1}$. The *meta*-disubstituted benzenes show two strong bands in the regions $680\text{--}725$ and $750\text{--}810\text{ cm}^{-1}$, whereas *para*-disubstituted benzenes exhibit only one band in the region $800\text{--}860\text{ cm}^{-1}$ (Table 3.1). Fig. 3.6 shows IR spectrum of a typical aromatic compound.

(vii) Alcohols and Phenols

Alcohols and phenols show characteristic bands arising from O—H stretching and C—O stretching in the regions $3200\text{--}3650$ and $1000\text{--}1260\text{ cm}^{-1}$, respectively (Table 3.1). In Section 3.7(iii), we have already discussed the excellent hydrogen bonding property of alcohols and phenols. As we have seen, the non-hydrogen-

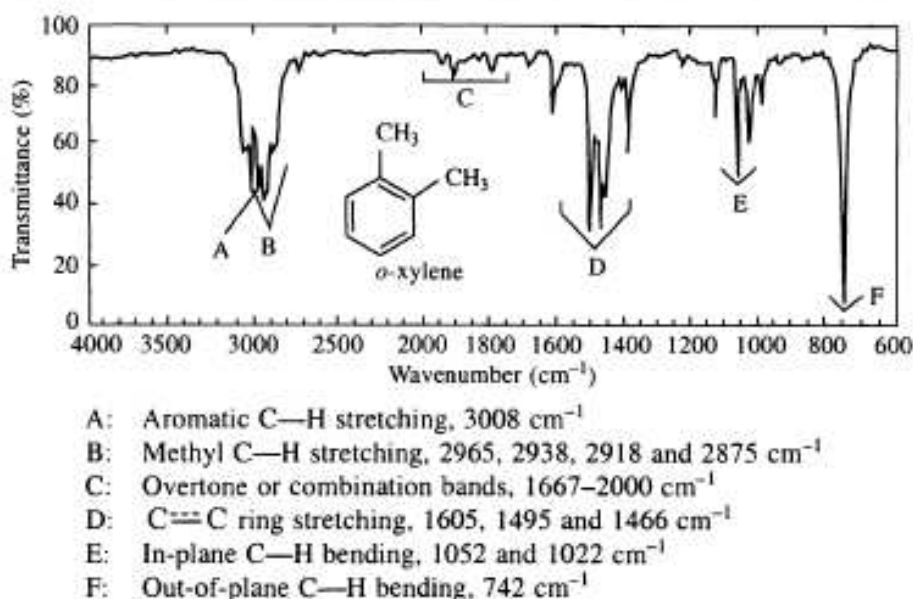

Fig. 3.6 IR spectrum of *o*-xylene, neat

bonded hydroxyl groups of alcohols and phenols strongly absorb in the region $3590\text{--}3650\text{ cm}^{-1}$, whereas their free O—H stretching bands appear in the region $3200\text{--}3600\text{ cm}^{-1}$. We should note that the frequency of O—H stretching band depends on concentration, nature of the solvent and temperature because these factors affect the hydrogen bonding which affects the absorption frequency.

IR spectra of alcohols and phenols exhibit a strong band in their IR spectra due to their C—O stretching vibrations in the region $1000\text{--}1260\text{ cm}^{-1}$. Primary, secondary and tertiary alcohols can be recognized with the help of their O—H stretching and C—O stretching bands (Table 3.1). The O—H in-plane bending vibrations occur in the region $1330\text{--}1420\text{ cm}^{-1}$. Alcohols and phenols in the liquid state show a broad absorption band in the region $650\text{--}769\text{ cm}^{-1}$ because of out-of-plane bending of hydrogen-bonded O—H group. Figs. 3.7 and 3.8 show IR spectra of a typical alcohol and a phenol, respectively.

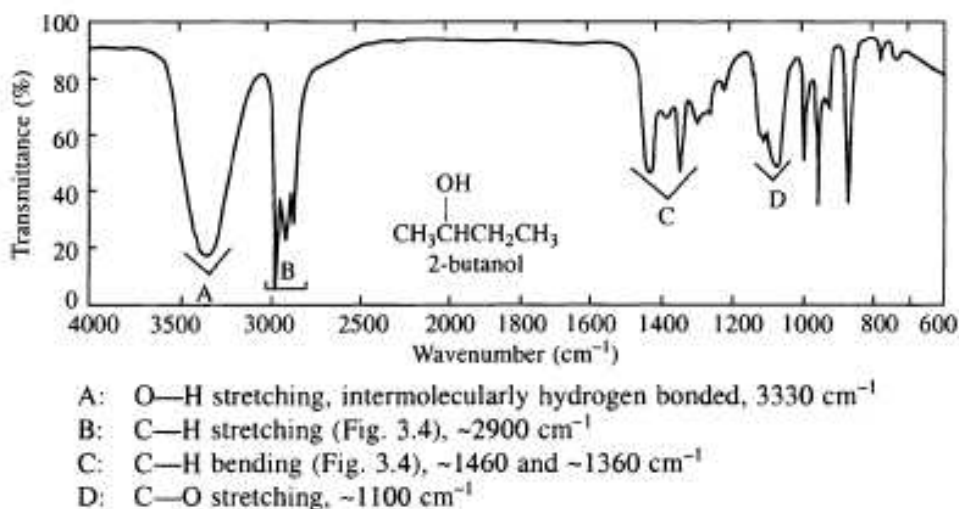
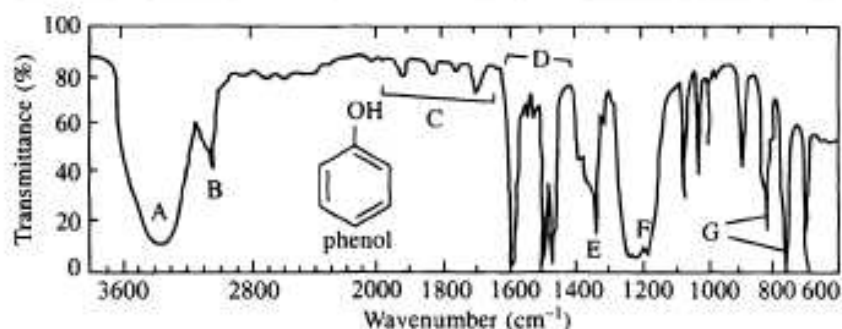

Fig. 3.7 IR spectrum of 2-butanol, neat



- A: Broad, intermolecularly hydrogen bonded, O—H stretching 3333 cm^{-1}
 B: Aromatic C—H stretching, 3045 cm^{-1}
 C: Overtone or combination bands (Fig. 3.6), $1667\text{--}2000\text{ cm}^{-1}$
 D: C=C ring stretching, $1580, 1495$ and 1468 cm^{-1}
 E: In-plane O—H bending, 1359 cm^{-1}
 F: C—O stretching, 1223 cm^{-1}
 G: Out-of-plane C—H bending, 805 and 745 cm^{-1}

Fig. 3.8 IR spectrum of phenol, melt

The axial or equatorial position occupied by the O—H group can be detected with the help of IR spectroscopy. The stretching absorption frequency of the axial O—H group is higher than that of the equatorial. This is due to the 1,3-diaxial interaction (i.e. the interaction between the axial O—H group and the axial hydrogen at position-3 with respect to this O—H group) which hinders the stretching vibration of the O—H group and thus its frequency is raised.

In 2,6-disubstituted phenols intermolecular hydrogen bonding is prevented by steric hindrance. Hence, no band due to hydrogen-bonded O—H stretching is observed in the region $3200\text{--}3600\text{ cm}^{-1}$. Thus, such phenols show a strong band near 3640 cm^{-1} . In case of 2-substituted phenols, some O—H groups are hydrogen bonded and some are free, hence bands due to both are observed, i.e. one band around 3640 cm^{-1} and the other near $3200\text{--}3600\text{ cm}^{-1}$. For example, 2,6-di-*t*-butyl phenol shows only one O—H stretching band at 3642 cm^{-1} , whereas 2-*t*-butyl phenol shows two O—H stretching bands, one at 3608 cm^{-1} and the other at 3643 cm^{-1} .

(viii) Ethers and Epoxides

Ethers exhibit characteristic C—O—C stretching bands (Table 3.1). The atomic masses of C and O are fairly comparable. Thus, their force constants are close, and so C—O—C and C—C—C stretchings have almost the same frequency. Since vibrations of C—O—C result in greater dipole moment changes than that of C—C—C due to greater electronegativity of oxygen, more intense IR bands are observed for ethers. Aliphatic ethers show a characteristic, strong band in the region $1060\text{--}1150\text{ cm}^{-1}$ because of asymmetrical C—O—C stretching. The symmetrical stretching band is usually weak and clearly appears in the Raman spectrum.

Epoxides (cyclic ethers) show two stretching bands, one near 1250 cm^{-1} owing to symmetrical stretching (ring breathing) and the other in the range

810–950 cm^{-1} due to asymmetrical ring stretching. Larger ring ethers absorb closer to the usual values for acyclic ethers.

(ix) Aldehydes and Ketones

Aldehydes, ketones, carboxylic acids, carboxylic esters, lactones, acid halides, anhydrides, amides and lactams show a strong $\text{C}=\text{O}$ stretching band generally in the region 1630–1870 cm^{-1} . This band has relatively constant position, high intensity and has far less interfering bands in its region making it one of the most readily recognizable bands in IR spectra. The $\text{C}=\text{O}$ stretching frequency depends on inductive effect, mesomeric effect, hydrogen bonding, field effect, steric effect and ring strain. These factors either increase or decrease the stretching frequency of both the aldehydic and ketonic $\text{C}=\text{O}$ groups compared to the normal value 1715 cm^{-1} (stretching absorption frequency of a neat sample of a saturated aliphatic ketone). Non-polar solvents increase, whereas polar solvents decrease the frequency of absorption but the overall range of solvent effect does not exceed 25 cm^{-1} . Figs. 3.9 and 3.10 show IR spectra of a typical aldehyde and a ketone, respectively.

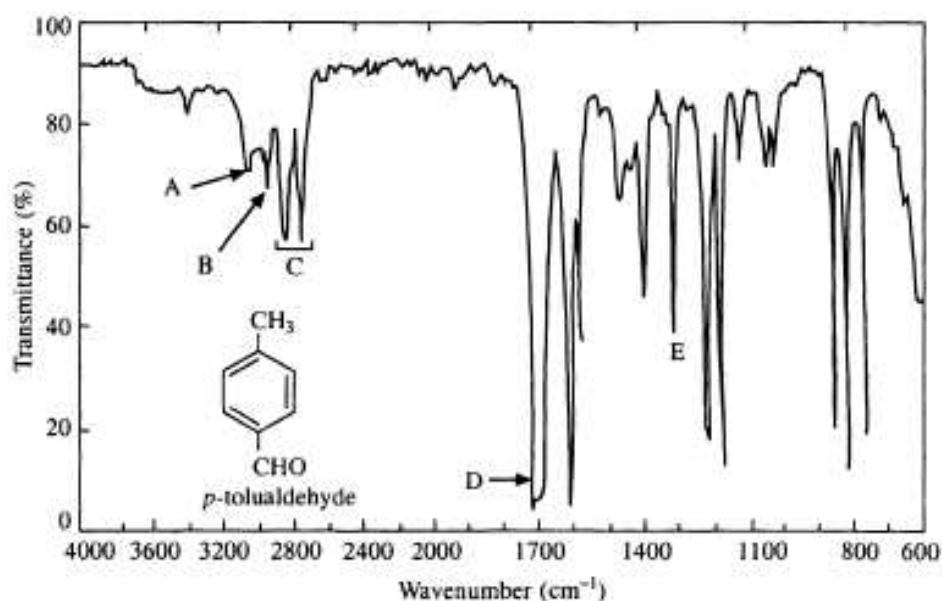

- A: Aromatic C—H stretching, near 3060 cm^{-1} (Fig. 3.6)
- B: Methyl C—H stretching, near 2950 cm^{-1} (Fig. 3.6)
- C: Aldehydic C—H stretching, 2825 and 2717 cm^{-1} ; doublet due to Fermi resonance with overtone of band at 1389 cm^{-1} (E)
- D: Conjugated aldehydic $\text{C}=\text{O}$ stretching, 1700 cm^{-1}
- E: Aldehydic C—H bending, 1389 cm^{-1}

Fig. 3.9 IR spectrum of *p*-tolualdehyde, neat

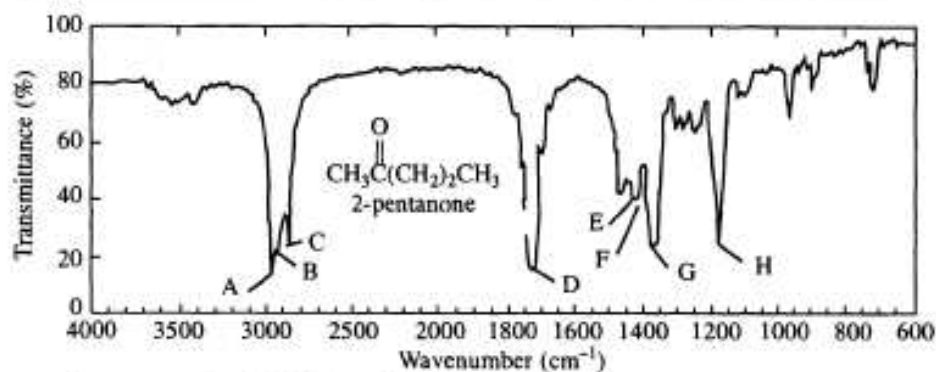

- A: ν_{as} , methyl, 2955 cm^{-1}
 B: ν_{as} , methylene, 2930 cm^{-1}
 C: ν_{s} , methyl, 2866 cm^{-1}
 D: Normal C=O stretching, 1725 cm^{-1}
 E: δ_{as} , CH₃, $\sim 1430\text{ cm}^{-1}$
 F: δ_{s} , CH₂, $\sim 1430\text{ cm}^{-1}$
 G: δ_{s} , CH₃ of CH₃CO unit, 1370 cm^{-1}
 H: C—CO—C stretching and bending, 1172 cm^{-1}

Fig. 3.10 IR spectrum of 2-pentanone, neat

As discussed in Section 3.7(iv), a carbonyl compound may be considered as a resonance hybrid of the following structures:

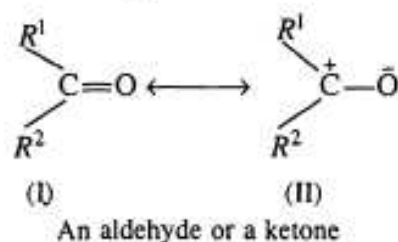

The $-I$ effect of R^1 and R^2 groups favour structure (I), whereas $+I$ effect of these groups favour structure (II). Thus, in the former the length of C=O bond is reduced resulting in the increase of its force constant and the frequency of absorption, whereas in the latter C=O bond is lengthened resulting in the decrease of its absorption frequency. Because of the larger $+I$ effect operating in ketones, their C=O stretching frequency is lower than that of aldehydes. As seen in Section 3.7(iv), conjugation of an aldehydic or ketonic carbonyl group with an olefinic double bond or an aromatic ring lowers the $\nu_{\text{C=O}}$ frequency due to mesomeric effect which reduces the double bond character (i.e. force constant) of the C=O group (Table 3.1).

Intermolecular hydrogen bonding between a C=O group and a hydroxylic solvent causes a slight decrease in the absorption frequency of the carbonyl group. The effect of intermolecular and intramolecular hydrogen bondings on carbonyl absorption has already been discussed in Section 3.7(iii). Similar is the case with aldehydes and ketones.

In the absence of steric hindrance, a conjugated system tends to remain in a planar conformation because it allows mesomerism, i.e. stabilization. Steric effects reduce the effect of conjugation by reducing the coplanarity of the conjugated

system. α,β -unsaturated ketones may exist in *s-cis* and *s-trans* conformations and then will show absorption for each of these forms. For example, benzalacetone is present in both the *s-cis* and *s-trans* form in carbon disulphide and shows absorption for each of these forms. Because of steric inhibition of mesomerism, the *s-cis* form has high value for C=O stretching frequency (1699 cm^{-1}) than that for the *s-trans* form (1674 cm^{-1}) where the double bond character of the C=O group is reduced by mesomerism causing the lowering of the absorption frequency.

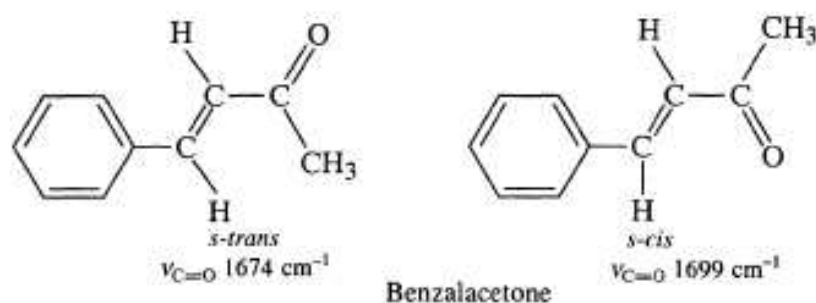

In α -halocyclohexanone, the equatorial halogen atom is near the carbonyl group and its negative field repels the non-bonding electrons of the carbonyl oxygen (field effect*). Thus, the force constant of the C=O bond is increased shifting its stretching band to a higher frequency. When α -halogen is in axial position, it is distant from the C=O group and so there is no field effect resulting in the shift of the absorption band.

The carbonyl stretching frequency in cyclic ketones having ring strain is shifted to a higher value. The C—CO—C bond angle in strained rings is reduced below the normal value of 120° (acyclic and six-membered cyclic ketones have the normal C—CO—C angle of 120°). This leads to an increase in *s* character in the sp^2 orbital of carbon involved in the C=O bond. Hence, the C=O bond is shortened (strengthened) resulting in an increase in the $\nu_{\text{C=O}}$ frequency. This increase in the *s* character of the outside sp^2 orbital is there because it gives more *p* character to the sp^2 orbitals of the ring bonds which relieves some of the strain, as the preferred bond angle of *p* orbitals is 90° . In ketones where C—CO—C angle is greater than the normal angle (120°), an opposite effect operates and they have lower $\nu_{\text{C=O}}$ frequency. For example, in di-*t*-butyl ketone, where the C—CO—C angle is pushed outward above 120° , has very low $\nu_{\text{C=O}}$ frequency (1698 cm^{-1}).

In another explanation, it has been suggested that the C=O stretching is influenced by the adjacent C—C stretching. In strained rings, the interaction with C—C bond stretching increases the energy required to cause C=O stretching and thus increases its frequency.

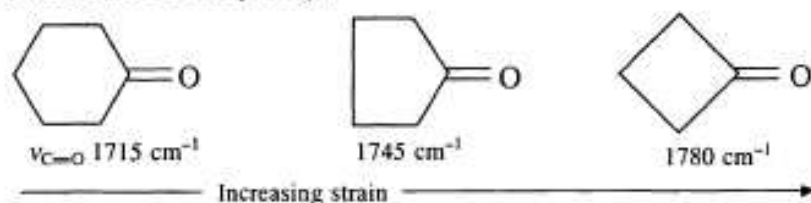

*Field effect is the electrostatic interaction of two charged centres within the same molecule through space or through solvent.

Quinones having both C=O groups in the same ring show characteristic absorption bands due to C=O and C=C stretchings in the region 1660–1690 cm^{-1} and near 1600 cm^{-1} , respectively. Quinones with extended conjugation in which the carbonyl groups are present in different rings absorb in the region 1635–1655 cm^{-1} (Table 3.1).

Most of the aldehydes exhibit aldehydic $\nu_{\text{C-H}}$ absorption as a doublet in the region 2700–2900 cm^{-1} (Fig. 3.9). The appearance of doublet is due to Fermi resonance between the fundamental aldehydic C—H stretch and the first overtone of bending vibration which usually appears around 1390 cm^{-1} . The aldehydes whose C—H bending is shifted considerably from 1390 cm^{-1} show only one $\nu_{\text{C-H}}$ band (Table 3.1).

(x) Carboxylic Acids and Carboxylate Anions

Carboxyl group (—COOH) is the functional group which can be most easily detected by IR spectroscopy. This is because the $\nu_{\text{C=O}}$ absorption occurs in the region (1655–1740 cm^{-1}) having far less interfering bands and in addition, it shows a broad $\nu_{\text{O-H}}$ band in the region 2500–3000 cm^{-1} (Table 3.1). Due to strong hydrogen bonding, carboxylic acids exist as dimers (Section 3.7(iii)) in the liquid or solid state and in concentrated CCl_4 solution ($> 0.01 \text{ M}$). Carboxylic acid dimers show very broad, intense $\nu_{\text{O-H}}$ absorption in the region 2500–3000 cm^{-1} , whereas that of the monomer appears at $\sim 3550 \text{ cm}^{-1}$. The $\nu_{\text{C=O}}$ absorption of the dimer of saturated aliphatic acid appears at $\sim 1710 \text{ cm}^{-1}$, whereas that of the monomer at $\sim 1760 \text{ cm}^{-1}$. The carboxylic acid dimer has centre of symmetry. Thus, only asymmetrical C=O stretching vibration absorbs in the infrared. The lower $\nu_{\text{C=O}}$ absorption frequency of carboxylic acid dimers is due to hydrogen bonding and resonance which lengthen (weaken) the C=O bond.

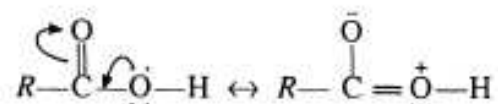

Resonating structures of a carboxylic acid

The α , β -unsaturated acids and aryl acids show $\nu_{\text{C=O}}$ absorption at more lower frequency because of the mesomeric effect which decreases the double bond character of the C=O bond and hence the force constant is decreased. Fig. 3.11 shows IR spectrum of a typical carboxylic acid.

The carboxylate anion is a resonance hybrid of the following equivalent resonating structures:

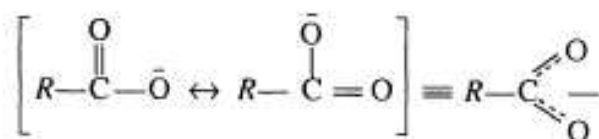

Resonating structures of the carboxylate anion

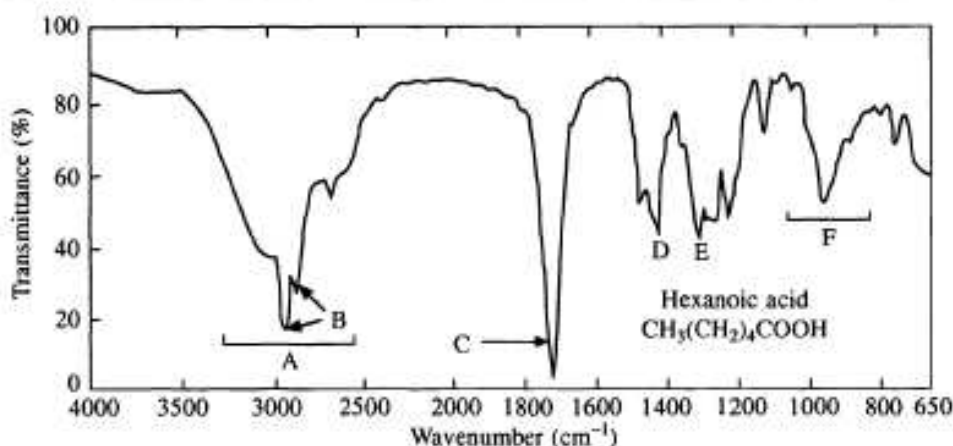

- A: Broad O—H stretching 2500–3300 cm^{-1}
 B: C—H stretching (superimposed upon O—H stretching) 2950, 2920 and 2850 cm^{-1}
 C: Normal, dimeric carboxylic C=O stretching, 1715 cm^{-1}
 D: O—H in-plane bending, 1408 cm^{-1}
 E: C—O stretching, 1280 cm^{-1}
 F: O—H out-of-plane bending, 930 cm^{-1}

Fig. 3.11 IR spectrum of hexanoic acid, neat

We know that resonance is much more important between the exactly equivalent structures as in the carboxylate anion than between non-equivalent structures as in the carboxylic acid. Thus, the decrease in the double bond character of the C=O group by resonance is greater in the carboxylate anion than that in the carboxylic acid. Thus, the $\nu_{\text{C=O}}$ absorption occurs at a lower wavenumber for a carboxylate anion than that for a carboxylic acid. The carboxylate anion gives two bands, a strong asymmetrical stretching band near 1550–1650 cm^{-1} and a weaker symmetrical stretching band near 1300–1400 cm^{-1} (Table 3.1). A suspected carboxylic acid structure may be confirmed by comparison of IR spectrum of the compound recorded in a neutral solvent (or as a neat sample) with that recorded in the presence of a base such as triethyl amine. The carboxylate ion thus formed also shows an additional ammonium band in the region 2200–2700 cm^{-1} .

(xi) Esters and Lactones

Esters and lactones (cyclic esters) have two characteristic, strong bands due to C=O and C—O stretchings. Saturated aliphatic esters (except formates) show $\nu_{\text{C=O}}$ absorption bands in the region 1735–1750 cm^{-1} . The $\nu_{\text{C=O}}$ bands of formates, α,β -unsaturated and aryl esters appear in the relatively lower region 1715–1730 cm^{-1} because of mesomeric effect. The force constant of the C=O bond in esters is increased due to the $-I$ effect of the adjacent oxygen. Thus, $\nu_{\text{C=O}}$ band of esters appear at a higher wavenumber than that of a ketone. The stretching frequency of the ester C=O group is influenced by various factors almost in the same way as that of ketones. The $\nu_{\text{C=O}}$ bands of esters occur in the region 1000–1300 cm^{-1} (Table 3.1). Fig. 3.12 shows IR spectrum of a typical ester.

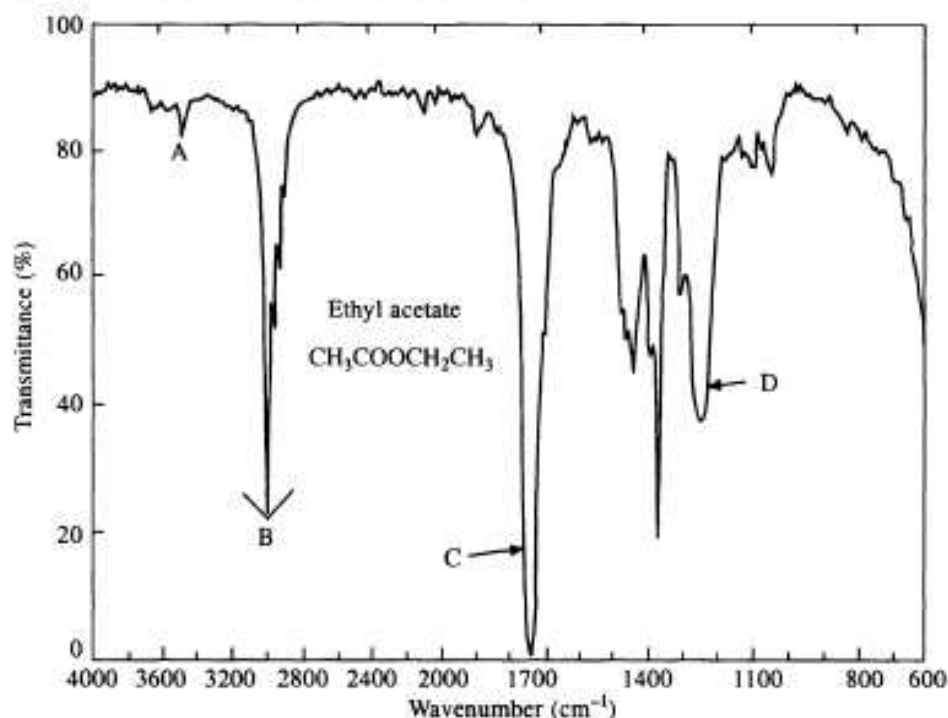

- A: Overtone band of C=O stretching, frequency twice that of C=O stretching, 3478 cm^{-1}
 B: Methyl and methylene stretching bands, around 2900 cm^{-1}
 C: Normal ester C=O stretching, 1740 cm^{-1}
 D: C—O—C stretching, 1259 cm^{-1}

Fig. 3.12 IR spectrum of ethyl acetate, neat

When a C=C or an aromatic ring is attached to the oxygen of the C—O group of an ester or lactone, there is a marked increase in the carbonyl frequency along with a decrease in the C—O frequency. This is because of the mesomeric effect as shown below which increases the force constant of the C=O bond and decreases that of the C—O bond

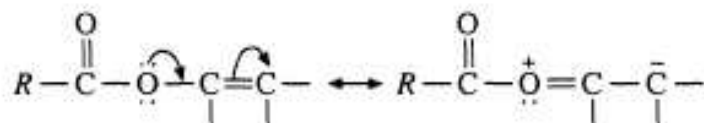

Saturated δ -lactones (six-membered ring) show the carbonyl absorption in the same region as straight-chain, unconjugated esters. Similar to that of ketones (Section 3.8(ix)), as ring strain in lactones increases, the carbonyl stretching frequency also increases.

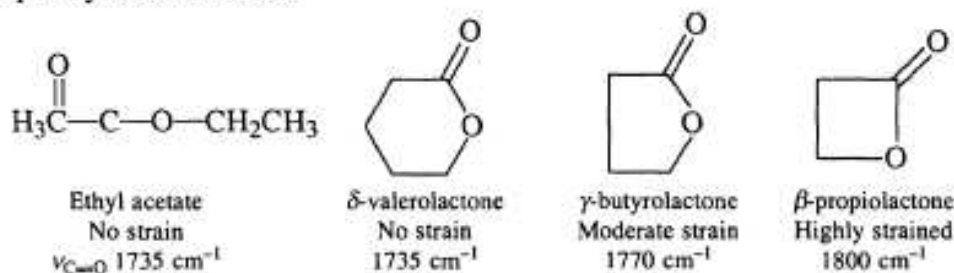

Unsaturated α to the $C=O$ group decreases the $C=O$ absorption frequency through mesomerism. Unsaturated α to the $-O-$ group increases the $\nu_{C=O}$ frequency and decreases the ν_{C-O} frequency through resonance in the same way as shown for acyclic esters, for example

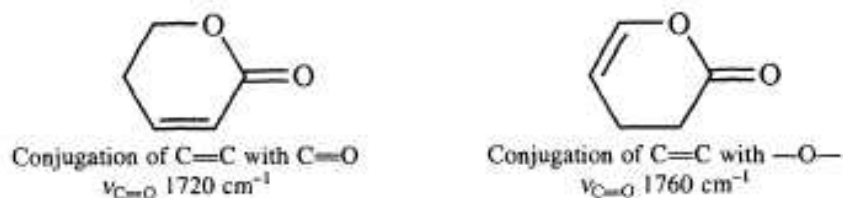

(xii) Acid Halides

Acid halides show strong $C=O$ absorption band in the carbonyl stretching region (Table 3.1). Unconjugated acid chlorides show $\nu_{C=O}$ band in the region 1790–1815 cm^{-1} . Since the resonance reduces the force constant of the $C=O$ bond, conjugated acid halides absorb at slightly lower frequency. For example, aromatic acid chlorides absorb strongly in the region 1750–1800 cm^{-1} . The decreasing order of $\nu_{C=O}$ frequency of various acid halides is as follows:



(xiii) Acid anhydrides

Acid anhydrides show two bands in the carbonyl region—one due to symmetrical and the other due to asymmetrical stretching of the $C=O$ group (Table 3.1). Saturated acyclic anhydrides show two $\nu_{C=O}$ bands in the region 1710–1825 cm^{-1} (Fig. 3.13) due to strong vibrational coupling of the two carbonyl groups through the oxygen as discussed in Section 3.7(a). Aryl and α,β -unsaturated anhydrides show $\nu_{C=O}$ bands in relatively lower regions due to resonance which decreases the force constant of the $C=O$ bond. In acyclic anhydrides, the high

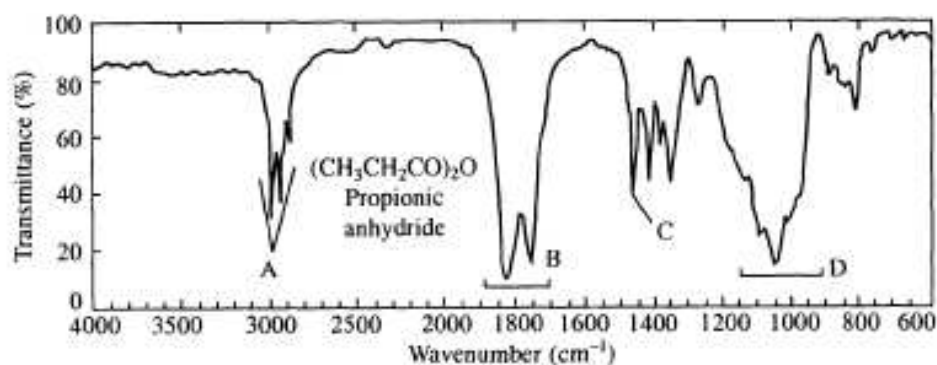

- A: C—H stretching, 2990, 2950 and 2880 cm^{-1}
 B: Asymmetrical and symmetrical $C=O$ coupled, 1825 and 1758 cm^{-1} , respectively
 C: δ_s CH_2 (scissoring), 1465 cm^{-1}
 D: C—CO—O—CO—C stretching, 1040 cm^{-1}

Fig. 3.13 IR spectrum of propionic anhydride, neat

frequency $\nu_{C=O}$ band is more intense, whereas the low frequency $\nu_{C=O}$ band is more intense in cyclic anhydrides. This characteristic can be used for differentiating acyclic and cyclic anhydrides. In cyclic anhydrides, both the $\nu_{C=O}$ bands shift towards higher frequencies than that of acyclic anhydrides. Cyclic anhydrides with five-membered rings show $\nu_{C=O}$ absorption at higher wavenumbers than acyclic anhydrides due to ring strain (Table 3.1). All types of anhydrides exhibit one or two strong $\nu_{C=O}$ bands in the region $1050\text{--}1300\text{ cm}^{-1}$.

(xiv) Amides, Lactams and Imides

We have already discussed in Section 3.7(d) that amides show $\nu_{C=O}$ band at a lower frequency than that of esters due to lesser electronegativity of nitrogen than oxygen. All amides show a $\nu_{C=O}$ band in the region $1630\text{--}1700\text{ cm}^{-1}$ which is known as the amide I band (Table 3.1). The absorption frequency of this band decreases on hydrogen bonding. Primary amides show two ν_{N-H} bands due to symmetrical and asymmetrical stretchings, whereas secondary amides and lactams (cyclic amides) show only one ν_{N-H} band (Table 3.1). The frequency of ν_{N-H} absorption bands is also reduced by hydrogen bonding though to a lesser degree than that of ν_{O-H} . Fig. 3.14 shows IR spectrum of a typical amide.

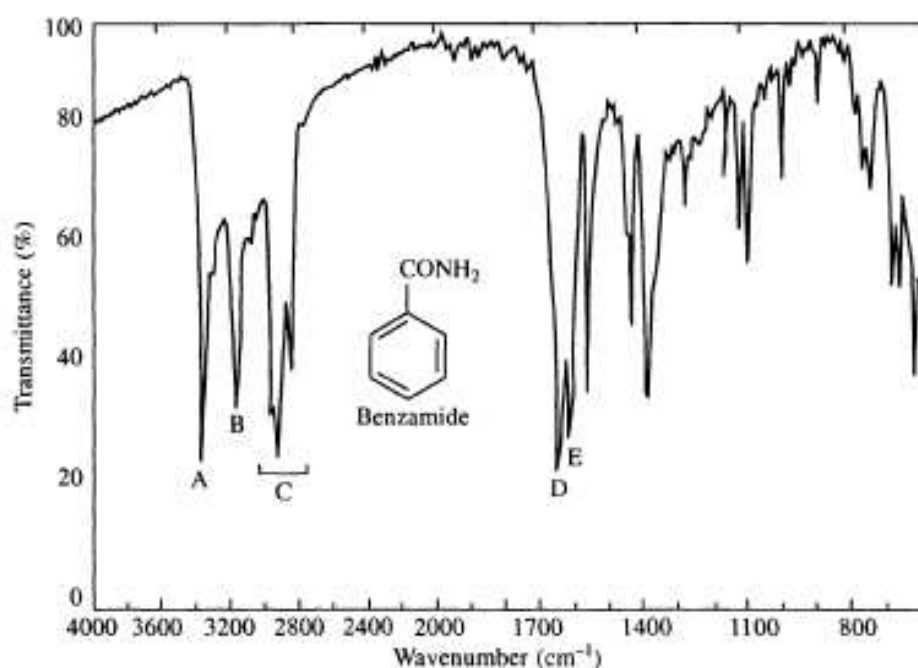

N—H stretching, coupled, primary amide, hydrogen bonded:

A: Asymmetric, 3370 cm^{-1}

B: Symmetric, 3170 cm^{-1}

C: Nujol and aromatic ν_{C-H} bands, $2860\text{--}3030\text{ cm}^{-1}$

D: C=O stretching, amide I band, 1660 cm^{-1}

E: N—H bending, amide II band, 1631 cm^{-1}

Fig. 3.14 IR spectrum of benzamide, as a nujol mull

In dilute solutions, primary and secondary amides and a few lactams exhibit a band or bands (amide II band) mainly due to NH_2 or NH bending in the region

1510–1650 cm^{-1} . Amide I band is generally more intense than amide II band. In solid state, amide I and II may overlap.

The frequency of $\nu_{\text{C=O}}$ absorption in lactams depends on the ring size. Similar to that of ketones and lactones (Sections 3.8(i) and 3.8(k)), as the ring strain in lactams increases, the carbonyl stretching frequency also increases. Fusion of the lactam ring with another ring generally increases $\nu_{\text{C=O}}$ frequency by 20–50 cm^{-1} . For example, in penicillin this absorption occurs at 1770 cm^{-1} .

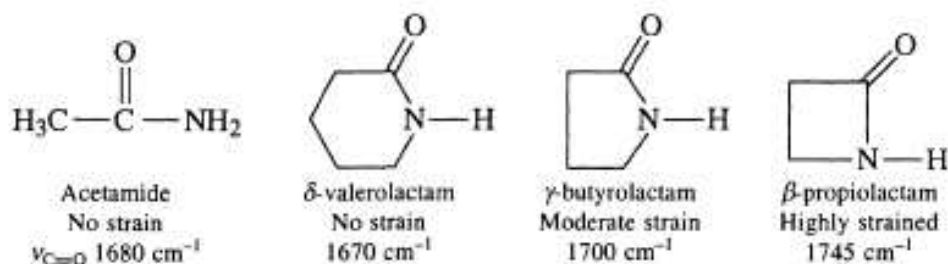

In cyclic imides, the $\nu_{\text{C=O}}$ frequency decreases with increasing ring size, whereas it is shifted to a higher value with α,β -unsaturation. For example, succinimide shows two strong C=O bands at ~ 1770 and 1700 cm^{-1} , whereas benzimide shows at ~ 1730 and 1670 cm^{-1} .

Summary of carbonyl absorptions

Effects of structural variations on the C=O stretching frequencies may be summarized as follows:

- (i) The greater the electronegativity of the group X in the compound RCOX , the higher is the frequency.
- (ii) α,β -unsaturation causes a lowering of frequency by 15–40 cm^{-1} . Amides are exceptions, where little shift is observed and that too usually to a higher frequency.
- (iii) Additional conjugation has relatively little effect.
- (iv) Hydrogen bonding to a carbonyl group shifts its frequency to a lower value by 40–60 cm^{-1} . Carboxylic acids, amides, enolized β -keto compounds and *o*-hydroxy and *o*-aminophenyl carbonyl compounds show this effect. In the solid state, the carbonyl stretching frequency of all the carbonyl compounds is slightly lowered compared to that in dilute solutions.
- (v) Ring strain in cyclic compounds causes large shift towards higher frequency. This provides a reliable test for distinguishing clearly between four, five and larger membered ring ketones, lactones and lactams. Six-membered ring and larger membered ring ketones, lactones and lactams show the normal frequency found for the corresponding open-chain compounds.
- (vi) When more than one structural influences are operating on a particular carbonyl group, the net effect is usually almost additive.

(xv) Amines and their Salts

Amines show characteristic $\nu_{\text{N-H}}$ absorption in the region 3300–3500 cm^{-1} . The position of absorption is affected by hydrogen bonding. In dilute solution, primary amines exhibit two sharp bands due to symmetrical and asymmetrical stretchings,

secondary amines give only one weak band, whereas tertiary amines give no band due to free N—H stretching in the region $3300\text{--}3500\text{ cm}^{-1}$ (Table 3.1). These bands are shifted to lower wavenumbers due to hydrogen bonding. Aromatic primary amines show $\nu_{\text{N—H}}$ bands at slightly higher wavenumbers. Fig. 3.15 shows a typical IR spectrum of an amine.

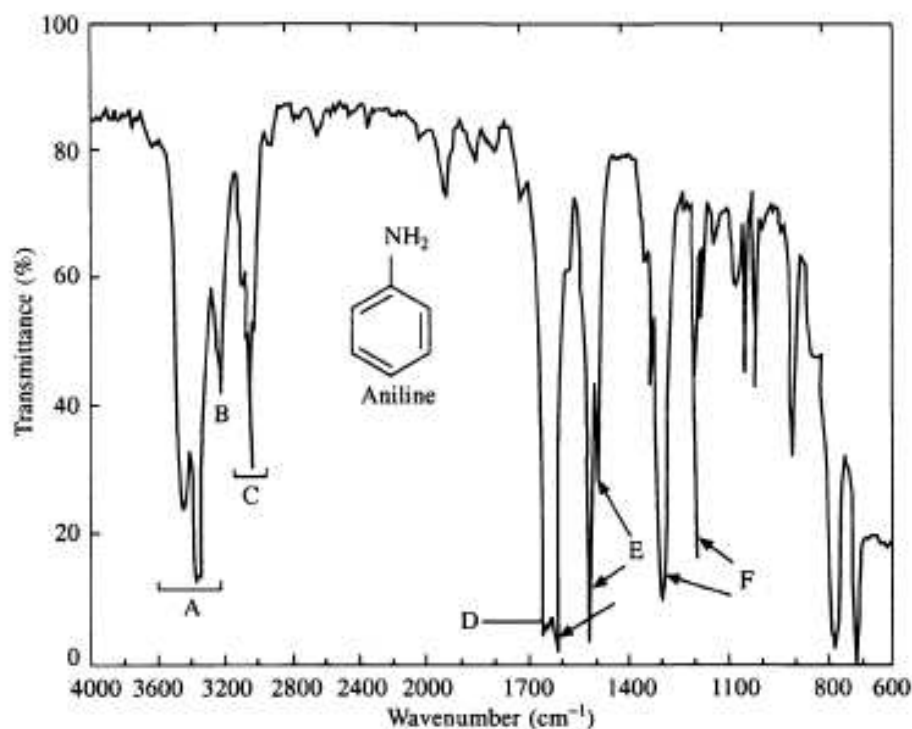

- A: N—H stretching, hydrogen bonded, primary amine coupled doublet asymmetrical 3440 cm^{-1} , symmetrical 3350 cm^{-1}
 B: Fermi resonance band, 3200 cm^{-1} ; with overtone of band at 1620 cm^{-1} (E)
 C: Aromatic C—H stretch, around 3050 cm^{-1}
 D: N—H bending, 1620 cm^{-1}
 E: C=C ring stretching, 1600 , 1500 and 1468 cm^{-1}
 F: C—N stretching, 1280 and 1175 cm^{-1}

Fig. 3.15 IR spectrum of aniline, neat

The N—H bending vibration of primary amines appears in the region $1590\text{--}1650\text{ cm}^{-1}$. This band moves to slightly higher frequency on hydrogen bonding. The N—H bending band is seldom detectable in the IR spectra of aliphatic secondary amines.

Salts of primary amines show strong, broad band due to N^+H_3 symmetrical and asymmetrical stretchings in the region $2700\text{--}3000\text{ cm}^{-1}$, whereas salts of secondary and tertiary amines absorb in the region $2250\text{--}2700\text{ cm}^{-1}$. In addition, bending N—H vibrations occur in amine salts in the region $1500\text{--}1600\text{ cm}^{-1}$. All the amines and amine salts show bands due to C—N vibrations in the fingerprint region.

(xvi) Amino Acids and their Salts

Amino acids exist in the following three forms as:

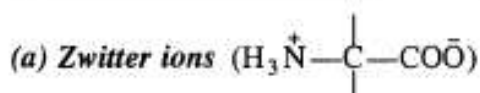

These show characteristic absorptions due to N^+H_3 and COO^- groups. A broad, strong N^+H_3 stretching band is observed in the region $3030\text{--}3130\text{ cm}^{-1}$. The COO^- group absorbs strongly in the region $1590\text{--}1600\text{ cm}^{-1}$ and more weakly near 1400 cm^{-1} due to $\text{C}=\text{O}$ asymmetrical and symmetrical stretchings, respectively.

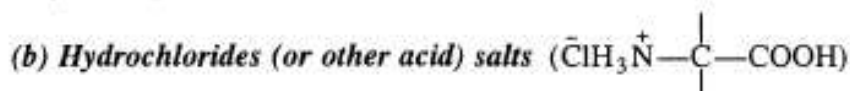

In these, the $\nu_{\text{C}=\text{O}}$ bands are shifted to higher frequencies. Hydrochlorides of α -amino acids show strong carbonyl absorption in the range $1730\text{--}1755\text{ cm}^{-1}$. Superimposed O—H and N^+H_3 stretching bands appear as a broad strong band in the region $2380\text{--}3333\text{ cm}^{-1}$.

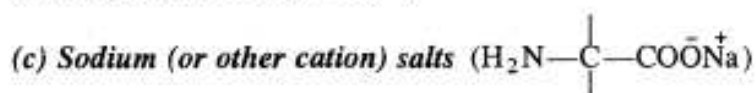

These salts exhibit the normal $\nu_{\text{N}-\text{H}}$ band in the range $3200\text{--}3400\text{ cm}^{-1}$ similar to other amines. The characteristic COO^- stretching bands appear near $1590\text{--}1600\text{ cm}^{-1}$ and near 1400 cm^{-1} .

In addition, all the three forms of amino acids show weak, asymmetrical bending band near $1590\text{--}1610\text{ cm}^{-1}$ and a relatively strong symmetrical bending band near $1481\text{--}1550\text{ cm}^{-1}$ due to N^+H_3 (or NH_2) bendings (Table 3.1).

(xvii) Nitro Compounds and Nitrites

Nitro compounds are considered to be a resonance hybrid of the following structures:

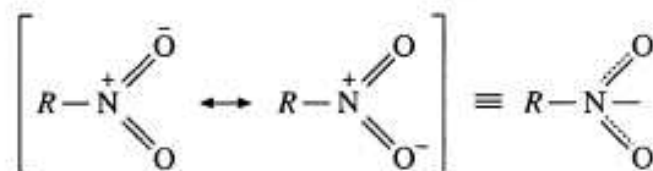

Reasoning structures of a nitro compound

Nitroalkanes exhibit two bands near 1550 and 1370 cm^{-1} due to asymmetrical and symmetrical stretching of the $\text{N}=\text{O}$ group, respectively. Conjugation lowers the frequency of both the bands causing absorption in the regions near $1500\text{--}1550\text{ cm}^{-1}$ and near $1290\text{--}1360\text{ cm}^{-1}$ (Table 3.1). Aromatic nitro compounds absorb around the same frequencies as conjugated aliphatic nitro compounds. Following is the order of $\nu_{\text{N}=\text{O}}$ frequency of nitro compounds:

primary > secondary > tertiary

Nitrites ($\text{R}-\text{O}-\text{N}=\text{O}$) show two strong $\nu_{\text{C}=\text{O}}$ bands at higher frequencies than that of the nitro compounds. They exhibit one band near $1650\text{--}1680\text{ cm}^{-1}$ and the other near $1611\text{--}1625\text{ cm}^{-1}$. The nitrite absorption bands are one of the strongest bands observed in IR spectra.

(xviii) Nitriles and Related Compounds

Nitriles show weak to medium $\nu_{C\equiv N}$ band in the region 2200–2260 cm^{-1} . Conjugated nitriles show absorption band in the lower end of this wavenumber region due to resonance which decreases the triple bond character of the $C\equiv N$ group. Occasionally, the $\nu_{C\equiv N}$ band is very weak or absent, e.g. some cyanohydrins show no $\nu_{C\equiv N}$ absorption.



Resonating structures of conjugated nitrile



Isocyanides (isonitriles), cyanates, isocyanates, thiocyanates isothiocyanates, azides and carbodiimides show absorption band in the region 1990–2275 cm^{-1} (Table 3.1) due to the $C\equiv N$ or cumulated double bond stretching. Schiff bases, oximes and thiazoles, etc. exhibit $\nu_{C=N}$ absorption in the region 1470–1690 cm^{-1} .

The $N=N$ stretching absorption of symmetrical diazo compounds is either very weak or inactive in IR but appears in the Raman spectrum near $\sim 1575 \text{ cm}^{-1}$. The bands are weak due to the non-polar nature of the bonds. Diazonium salts absorption band due to $-\text{N}^+\equiv\text{N}$ is near 2260 cm^{-1} .



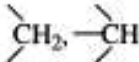
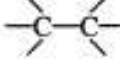

(xix) Sulphur and Phosphorus Compounds

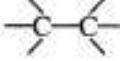
For characteristic absorption frequencies of sulphur or phosphorus containing groups, see at the end of Table 3.1.

Table 3.1 Characteristic infrared absorption frequencies

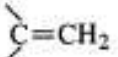
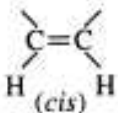
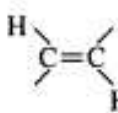
Type	Group	Absorption frequency (cm^{-1})	Intensity*	Assignment and remarks
Alkanes	$-\text{CH}_3$, 	2840–3000	$m \rightarrow s$	C—H stretch; two or three bands
		800–1200	w	C—C stretch; of little value
	$-\text{CH}_3$	1430–1470 1370–1380	m s	Asym. C—H bending Sym. C—H bending; very characteristic
		1445–1485	m	Asym. C—H bending
		~1340	w	C—H bending
		below 500	w	C—C bending; outside the ordinary IR region
Cycloalkanes	$-\text{CH}_2-$	2840–3050	m	Asym. and sym. C—H stretch; two bands

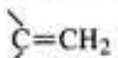
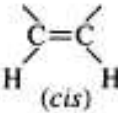
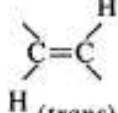
(Contd.)

Type	Group	Absorption frequency in cm^{-1}	Intensity*	Assignment and remarks	
	$-\text{CH}_2-$ (cyclopropane)	3040–3060 2975–2985 1015–1045	<i>m</i> <i>m</i> <i>m</i>	Asym. C—H stretch Sym. C—H stretch Skeletal vibration	
Alkenes		1620–1680	<i>v</i>	C=C stretch; in dienes, trienes etc., 1650 (<i>s</i>) and 1600 (<i>s</i>); on conjugation with aromatic ring, ~1625 (<i>m</i>); in α,β -unsaturated carbonyl compounds, 1590–1640 (<i>s</i>)	
		1640–1660	<i>m</i>		
		1655–1660	<i>m</i>		
		1670–1675	<i>w</i>		
		3000–3100	<i>m</i>		C—H stretch; almost the same position in the <i>cis</i> and <i>trans</i> isomers
		885–895	<i>s</i>		C—H out-of-plane bending
	RCH = CH ₂	985–995 900–940	<i>s</i> <i>s</i>		
		675–730	<i>m</i>		
		960–970	<i>s</i>		
		790–840	<i>m</i>		
(trisubstituted)					
Alkynes	$-\text{C}\equiv\text{C}-$	2100–2260	<i>v</i>	$\text{C}\equiv\text{C}$ stretch	
	$-\text{C}\equiv\text{C}-\text{H}$ (terminal)	2100–2140	<i>s</i>	$\text{C}=\text{C}$ stretch	

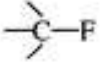
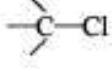
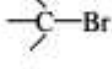
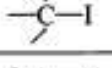
Type	Group	Absorption frequency in cm^{-1}	Intensity*	Assignment and remarks
	$\text{—C}\equiv\text{C—}$ (non-terminal)	2190–2260	<i>v</i>	$\text{C}\equiv\text{C}$ stretch; intensity of band decreases as symmetry of molecule increases; may be absent if the molecule is symmetrical about the triple bond
	$\text{—C}\equiv\text{C—H}$	3300–3310	<i>s</i>	C—H stretch
		615–645	<i>s</i>	C—H bending; outside the ordinary IR region
Halogen compounds ($X = \text{F, Cl, Br, I}$)	$\text{CH}_3\text{—X}$	near 3000	<i>s</i>	Asym. and sym. C—H stretch
		1000–1400	<i>s</i>	C—F stretch
		600–800	<i>s</i>	C—Cl stretch
		500–750	<i>s</i>	C—Br stretch
		~500	<i>s</i>	C—I stretch
	$\text{CH}_3\text{—X}$ ($X = \text{F, Cl, Br, I}$)	1441–1471	<i>v</i>	C—H asym. bending
		1255–1475	<i>v</i>	C—H sym. bending
Aromatic compounds	Aromatic C—H	3000–3100	<i>m</i>	C—H stretch
	Aromatic C—C	1600±5	<i>v</i>	$\text{C}=\text{C}$ skeletal stretch
		1580±5	<i>m</i>	Skeletal stretch; present when ring is further conjugated
		1500 ± 25	<i>v</i>	Skeletal stretch
		1450 ± 10	<i>m</i>	Skeletal stretch
	Monosubstituted benzenes	730–770	<i>s</i>	C—H out-of-plane bending
	<i>o</i> -disubstituted benzenes	690–710	<i>s</i>	
	<i>m</i> -disubstituted benzenes	735–770	<i>s</i>	
	<i>p</i> -disubstituted benzenes	750–810	<i>s</i>	
		680–725	<i>m</i> → <i>s</i>	
	Aromatic C—H	800–860	<i>s</i>	
	Aromatic C—H	1000–1300	<i>w</i>	In-plane C—H bending; usually difficult to assign because they are weak and C—O and other C—H bands occur in the same region

(Contd.)

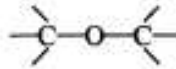
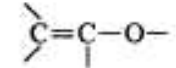
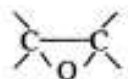
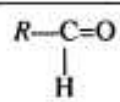
Type	Group	Absorption frequency in cm^{-1}	Intensity*	Assignment and remarks
Alcohols and phenols	O—H	3590–3650	<i>v</i>	Free O—H stretch
		3200–3600	<i>v</i>	Intermolecular hydrogen bonded O—H stretch
		2500–3200	<i>s</i>	Intramolecular hydrogen bonded O—H stretch
	C—O	1000–1260	<i>m</i> → <i>s</i>	C—O stretch
		~1050	<i>s</i>	C—O stretch primary alcohols
		~1100	<i>s</i>	C—O stretch secondary alcohols
		~1150	<i>s</i>	C—O stretch tertiary alcohols
		~1200	<i>s</i>	C—O stretch phenols
O—H	1330–1420	<i>s</i>	In-plane O—H bending	
	650–769	<i>s</i>	Out-of-plane O—H bending	
Ethers and epoxides	—O—CH ₃	2810–2850	<i>m</i>	C—H stretch
	—O—CH ₂ —	~3050	<i>m</i>	Epoxide C—H stretch
	—O—CH ₂ —O—	2770–2790	<i>m</i>	C—H stretch
		1060–1150	<i>s</i>	C—O—C asym. stretch
		1020–1075	<i>s</i>	C—O—C sym. stretch
	Aryl—O—	1200–1275	<i>s</i>	C—O—C asym. stretch
		1240–1260	<i>s</i>	C—O—C sym. stretch
		810–950	<i>m</i> → <i>s</i>	C—O—C asym. stretch; larger ring ethers absorb closer to the usual values for acyclic ethers
Aldehydes		1720–1740	<i>s</i>	C=O stretch; saturated, aliphatic
		1695–1715	<i>s</i>	C=O stretch; aromatic
		1680–1705	<i>s</i>	C=O stretch; α,β -unsaturated, aliphatic
		1660–1680	<i>s</i>	C=O stretch; $\alpha,\beta,\gamma,\delta$ -unsaturated, aliphatic
		1645–1670	<i>s</i>	C=O stretch; β -keto aldehyde in enol form; lowering caused by intramolecular hydrogen bonding
	2700–2900	<i>w</i>	C—H stretch; usually two	

Type	Group	Absorption frequency in cm^{-1}	Intensity*	Assignment and remarks
				bands, one near 2720 cm^{-1} due to Fermi resonance
Ketones	$\begin{array}{c} R \\ \diagdown \\ C=O \\ \diagup \\ R \end{array}$	1705–1725	<i>s</i>	C=O stretch; saturated, acyclic
		1680–1700	<i>s</i>	C=O stretch; aryl
		1660–1670	<i>s</i>	C=O stretch; diaryl
		1665–1685	<i>s</i>	C=O stretch; α, β -unsaturated, and $\alpha, \beta, \alpha', \beta'$ unsaturated, acyclic
		1705–1725	<i>s</i>	C=O stretch; six- and larger-membered ring
		1740–1750	<i>s</i>	C=O stretch; five-membered ring
		~1775	<i>s</i>	C=O stretch; four-membered ring
		1685–1705	<i>s</i>	C=O stretch; cyclopropyl
		1665–1685	<i>s</i>	C=O stretch; α, β -unsaturated cyclic, six- and larger-membered ring
		1708–1725	<i>s</i>	C=O stretch; five-membered ring
		1540–1640	<i>s</i>	C=O stretch; β -diketone, enolic
	<i>o</i> -amino- and <i>o</i> -hydroxy-aryl ketones	1635–1655	<i>s</i>	C=O stretch
	1,4- and 1,2-benzoquinones	1660–1690	<i>s</i>	C=O stretch
Carboxylic acids	—COOH	1700–1725	<i>s</i>	C=O stretch; saturated, aliphatic
		1690–1715	<i>s</i>	C=O stretch; α, β -unsaturated, aliphatic
		1680–1700	<i>s</i>	C=O stretch; aryl
		1720–1740	<i>s</i>	C=O stretch; α -halo
		1655–1665	<i>s</i>	C=O stretch; intramolecularly hydrogen-bonded
		2500–3000	<i>m</i>	O—H stretch; hydrogen-bonded, free O—H stretch, 3550 cm^{-1}

(Contd.)

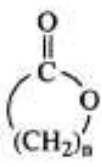
Type	Group	Absorption frequency in cm^{-1}	Intensity*	Assignment and remarks
Carboxylate anions	$-\text{COO}^-$	1550–1650	<i>s</i>	C=O asym. stretch
		1300–1400	<i>s</i>	C=O sym. stretch
Esters	$R-\text{COOR}'$	1735–1750	<i>s</i>	C=O stretch; saturated acyclic
		1715–1730	<i>s</i>	C=O stretch; $R = \alpha, \beta$ -unsaturated or aryl group
		1750–1800	<i>s</i>	C=O stretch; $R' = \alpha, \beta$ -unsaturated or aryl group
		1650	<i>s</i>	C=O stretch; β -ketoesters, enolic
		1000–1300	<i>s</i>	C—O—C sym. and asym. stretch; in all types of esters
Lactones (cyclic esters)		1735–1750	<i>s</i>	C=O stretch; δ -lactone and larger rings, $n \geq 4$
		1760–1780	<i>s</i>	C=O stretch; γ -lactone, $n = 3$
		1820–1840	<i>s</i>	C=O stretch; β -lactone, $n = 2$
		1717–1730	<i>s</i>	C=O stretch; α, β -unsaturated δ -lactone
		1740–1770	<i>s</i>	C=O stretch; α, β -unsaturated γ -lactone
		~1800	<i>s</i>	C=O stretch; β, γ -unsaturated γ -lactone
Acid halides	$-\text{COCl}$	1790–1815	<i>s</i>	C=O stretch; fluorides higher, bromides and iodides successively lower
		1750–1800	<i>s</i>	C=O stretch; aryl and α, β -unsaturated
Acid anhydrides	$-\text{CO}-\text{O}-\text{CO}-$	1800–1850	<i>s</i>	C=O stretch; two bands
		1740–1790	<i>s</i>	
		1780–1830	<i>s</i>	C=O stretch; two bands, aryl and α, β -unsaturated, acyclic
		1710–1770	<i>s</i>	
		1820–1870	<i>s</i>	C=O stretch; two bands, saturated five-membered ring
		1750–1800	<i>s</i>	
		1780–1830	<i>s</i>	C=O stretch; two bands, aryl and α, β -unsaturated
		1710–1770	<i>s</i>	
		1050–1300	<i>s</i>	

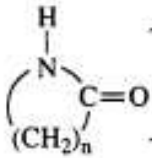
Type	Group	Absorption frequency in cm^{-1}	Intensity*	Assignment and remarks
Amides	$R-\text{CONH}_2$ (primary)	~1690	<i>s</i>	Amide I, $\text{C}=\text{O}$ stretch; free, i.e. in dil. solution
		~1650	<i>s</i>	$\text{C}=\text{O}$ stretch; associated, in solid state and conc. solution
	$R-\text{CONHR}$ (secondary)	1670–1700	<i>s</i>	$\text{C}=\text{O}$ stretch; free, i.e. in dil. solution
		1630–1680	<i>s</i>	$\text{C}=\text{O}$ stretch; associated, in solid state
	$R\text{CONR}_2$ (tertiary)	1630–1670	<i>s</i>	$\text{C}=\text{O}$ stretch; free and associated
	$R-\text{CONH}_2$	~3500	<i>m</i>	N—H stretching; free, two bands
		~3400	<i>m</i>	
		3350	<i>m</i>	
	$R-\text{CONHR}$	3180	<i>m</i>	N—H stretching; associated, two bands
		3430	<i>m</i>	
3140–3320		<i>m</i>	N—H stretch; free, one band	
				N—H stretch; associated, one band
	$R\text{CONH}_2$	1590–1620	<i>s</i>	Amide II, N—H bending; dil. solution
	$R\text{CONHR}$	1510–1550	<i>s</i>	Amide II, N—H bending; dil. solution
Lactams (cyclic amides)		~1680	<i>s</i>	$\text{C}=\text{O}$ stretch; $n \geq 4$ δ -lactam, dil. solution
		~1700	<i>s</i>	$\text{C}=\text{O}$ stretch; $n = 3$, γ -lactam, dil. solution
		1730–1760	<i>s</i>	β -lactam, $\text{C}=\text{O}$ stretch; $n = 2$, dil. solution
		~3400	<i>m</i>	N—H stretch; free lactam, associated, 3070–3175 cm^{-1}
Amines and their salts	RNH_2	3300–3500	<i>m</i>	N—H stretch; free, two bands due to sym. and asym. stretch
	R_2NH	3310–3550	<i>m</i>	N—H stretch; free, one band
	$\text{R}_2\text{C}=\text{NH}$ (imine)	3300–3400	<i>m</i>	N—H stretch; one band
	$\text{R}\overset{\oplus}{\text{N}}\text{H}_3$	~3000	<i>s</i>	$\overset{\oplus}{\text{N}}\text{H}_3$ sym. and asym. stretch

(Contd.)

Type	Group	Absorption frequency in cm^{-1}	Intensity*	Assignment and remarks
	$R_2\overset{+}{N}H_2$ and $R_3\overset{+}{N}H$	2250–2700	<i>s</i>	$\overset{+}{N}H_2$ and $\overset{+}{N}H$ stretch
	$\overset{+}{N}-CH_3$	2780–2820	<i>m</i>	C—H stretch
	$R NH_2$	1590–1650	$m \rightarrow s$	N—H in-plane bending
	R_2NH	1550–1650	<i>w</i>	N—H in-plane bending
	Amine salts	1575–1600	<i>s</i>	$\overset{+}{N}H_3$ and $\overset{+}{N}H_2$ bending
		~1500	<i>s</i>	$\overset{+}{N}H_3$ sym. bending
Amino acids and their salts	$H_3\overset{+}{N}-\overset{ }{\underset{ }{C}}-\overset{ }{\underset{ }{COO^-}}$	1590–1600 ~1400 3030–3130 1730–1755	<i>s</i> <i>w</i> <i>s</i> <i>s</i>	C=O asym. stretch C=O sym. stretch N—H stretch C=O stretch
	$Cl\overset{+}{N}H_3-\overset{ }{\underset{ }{C}}-\overset{ }{\underset{ }{COOH}}$	2380–3333	<i>s</i>	O—H and $\overset{+}{N}H_3$ stretch; superimposed
	$H_3N-\overset{ }{\underset{ }{C}}-\overset{ }{\underset{ }{COO^-Na^+}}$	1590–1600 ~1400 3200–3400	<i>s</i> <i>w</i> <i>s</i>	C=O asym. stretch C=O sym. stretch N—H stretch
	All amino acids and their salts	1590–1610 1481–1550	<i>w</i> <i>s</i>	NH_2 or $\overset{+}{N}H_3$ asym. bending NH_2 or $\overset{+}{N}H_3$ sym. bending
Nitro compounds and nitrites	$R-NO_2$ (aliphatic)	1550–1570 1370–1380	<i>s</i> <i>s</i>	Asym. N=O stretch Sym. N=O stretch
	$Ar-NO_2$ (aromatic)	1500–1570 1300–1370	<i>s</i> <i>s</i>	Asym. N=O stretch Sym. N=O stretch
	$-O-N=O$	1610–1680	<i>s</i>	N=O stretch; two bands
Nitriles and related compounds	$R-C\equiv N$ (nitriles)	2200–2260	<i>v</i>	C≡N stretch
	$R-N\equiv C$ (isonitriles)	2070–2220	<i>m</i>	N≡C stretch
	$R-S-C\equiv N$ (thiocyanates)	2140–2175	<i>s</i>	C≡N stretch
	$R-N=C=N-R$ (carbodiimides)	2130–2155	<i>s</i>	N=C=N stretch
	$R-N=C=O$ (isocyanates)	2240–2275	<i>m</i>	N=C=O stretch

Type	Group	Absorption frequency in cm^{-1}	Intensity*	Assignment and remarks
	$R-N=C=S$ (isothiocyanates)	1990–2140	<i>s</i>	$N=C=S$ stretch
	$R-N_3$ (azides)	2120–2160	<i>s</i>	N_3 stretch
	>C=N- (Schiff bases, imines and oximes)	1640–1690	<i>v</i>	$C=N$ stretch
	$R-\overset{+}{N}=N$ (diazonium salts)	2240–2280	<i>s</i>	$\overset{+}{N}=N$ stretch
	$R-N=N-R$ (azo compounds)	1575–1630	<i>v</i>	$N=N$ stretch
Sulphur compounds	$-SH$	2550–2600	<i>w</i>	$S-H$ stretch; less affected by hydrogen bonding
	>C=S	1050–1200	<i>s</i>	$C=S$ stretch
	$\begin{array}{c} \\ -C-N-H \\ \\ S \end{array}$	~3400	<i>m</i>	$N-H$ stretch; lowered to 3150 cm^{-1} in solid state
		1100–1300	<i>s</i>	Amide I, $C-S$ stretch
		1460–1550	<i>s</i>	Amide II, $N-H$ bending
	>S=O	1040–1060	<i>s</i>	$S=O$ stretch
	>SO_2	1300–1350	<i>s</i>	Asym. SO_2 stretch
		1120–1160	<i>s</i>	Sym. SO_2 stretch
	$-SO_2-N<$	1330–1370	<i>s</i>	Asym. SO_2 stretch
		1160–1180	<i>s</i>	Sym. SO_2 stretch
	$-SO_2-O-$	1330–1420	<i>s</i>	Asym. SO_2 stretch
		1145–1200	<i>s</i>	Sym. SO_2 stretch
Phosphorus compounds	$P-H$	2350–2440	<i>s</i>	$P-H$ stretch
	$P-O-R$	1030–1240	<i>s</i>	$P-O-C$ stretch
	$P=O$	1250–1300	<i>s</i>	$P=O$ stretch; in phosphate esters
	$\begin{array}{c} O \\ \diagup \\ P \\ \diagdown \\ OH \end{array}$	2560–2700	<i>v</i>	$O-H$ stretch; hydrogen bonded
		1180–1240	<i>s</i>	$P=O$ stretch

**s* = strong, *m* = medium, *w* = weak, *v* = variable.

3.9 Fingerprint Region

It is not possible for any two different compounds (except enantiomers) to have exactly the same IR spectrum. Therefore, the IR spectrum of a compound is called its *fingerprint*. The region below 1500 cm^{-1} is called fingerprint region because every compound has unique absorption pattern in this region, just as every person has unique fingerprints. The fingerprint region contains many absorption bands caused by bending vibrations as well as absorption bands caused by C—C, C—O like in alcohols, ethers, esters, etc. and C—N (e.g. in amines, amino acids, amides, etc.) stretching vibrations. Since the number of bending vibrations in a molecule is much greater than its stretching vibrations, the fingerprint region is rich in absorption bands and shoulders. Thus, the superimposability of IR bands of the spectra of any two different compounds becomes impossible in this region. However, similar compounds may show very similar spectra above 1500 cm^{-1} .

The use of IR spectroscopy to confirm the identity of a compound with the help of an authentic sample is more reliable than taking mixed m.p. or comparing other physical properties. If two pure samples give different IR spectra under same conditions, they represent different compounds. If the samples give the superimposable IR spectra, they represent the same compound. For example, the IR spectra of two stereoisomeric steroids, androsterone and epiandrosterone, show three strong bands above 1500 cm^{-1} , viz. around 3600 , 2950 and 1740 cm^{-1} due to O—H, C—H and C=O stretching vibrations, respectively. However, the absorption patterns in the fingerprint region of their IR spectra are quite different showing them to be different compounds. It should be noted that these two compounds differ only in the stereochemistry at C-3 where the OH group is axial in androsterone and equatorial in epiandrosterone.

3.10 Applications of Infrared Spectroscopy

Among all the properties of an organic compound, no single property gives as much information about the compound's structure as its infrared spectrum. Thus, IR spectroscopy is the most widely used method for structure determination of organic compounds. The basic reason why IR spectra are of such value to organic chemists is that molecular vibrations depend on interatomic distances, bond angles and bond strengths, rather than on bulk properties of the compound. Thus, these vibrational frequencies provide a molecular fingerprint which enables the identification of the compound either in the pure state or in mixtures. IR spectroscopy is especially used for detection of functional groups in organic compounds and for establishing the identity of organic compounds. Some important applications of IR spectroscopy to organic chemistry are summarized as follows.

(i) Detection of Functional groups

All functional groups absorb in a definite frequency region. Thus, the presence or absence of a band in a definite frequency region tells the presence or absence of a particular functional group in the compound. For example, the presence of a $\nu_{\text{C=O}}$ band in the region 1720 – 1740 cm^{-1} along with another band (usually two bands) in the region 2700 – 2900 cm^{-1} shows the presence of an aldehydic

carbonyl group in the compound. The normal absorption frequency of a particular group may change within its definite range. This change indicates the nature of the factor, such as inductive effect, conjugation, hydrogen bonding, steric effect and field effect, influencing the group frequency, thus giving an idea of the structure of the compound. A discussion on characteristic absorptions in various classes of organic compounds is given in Section 3.8, and characteristic group frequencies are summarized in Table 3.1. These are very useful for detecting various functional groups with the help of IR spectra.

(ii) Confirmation of the Identity of Compounds

The identity (and thus the purity) of a compound is often established by comparing its IR spectrum with that of an authentic sample. If the IR spectra, recorded under same conditions, are superimposable, they represent the same compound. The large number of bands, especially in the fingerprint region, are most useful for identification. This technique is more reliable than taking mixed m.p. or comparing other physical properties, particularly when only small quantities of a substance are available.

(iii) Estimation of the Purity of Samples

IR spectra of impure sample are usually blurred and have many bands which cannot be interpreted, whereas a pure compound gives a clear IR spectrum. For example, a sample of an alcohol containing a ketone as an impurity gives poor IR spectrum which shows additional absorption bands due to the carbonyl group. Similarly, the presence of a ketone as impurity in a sample of hydrocarbon can easily be detected because the hydrocarbons do not show any absorption band around 1715 cm^{-1} which is the characteristic band of a carbonyl group. The percentages of individual components in a mixture can be estimated by intensity measurements of specific absorption bands. Thus, the purity of a sample may be estimated by inspection of its IR spectrum and comparison with a reference spectrum.

(iv) Study of Hydrogen Bonding

As discussed in Section 3.7(iii), IR spectroscopy is useful in detecting hydrogen bonding, in estimating the strength of hydrogen bonds and in distinguishing intermolecular and intramolecular hydrogen bondings.

(v) Calculation of Force Constants

The frequencies of IR absorptions are commonly used to calculate the force constants of various bonds. For this purpose, Hooke's law as represented by Eq. (3.1) in Section 3.6 is applied.

(vi) Determination of Orientations in Aromatic Compounds

Absorptions in the region $675\text{--}900\text{ cm}^{-1}$ due to out-of-plane bending vibrations indicate the relative positions of substituents on the benzene ring. The position of absorption bands in this region depends on the number of adjacent hydrogen atoms on the ring. The *o*-disubstituted benzenes show a strong band in the region

735–770 cm⁻¹ but no band in the region 690–710 cm⁻¹. The *m*-disubstituted benzenes show two strong bands in the regions 680–725 and 750–810 cm⁻¹, whereas *p*-disubstituted benzenes exhibit only one band in the region 800–860 cm⁻¹.

(vii) Study of the Progress of Reactions

In most of the cases, the progress of an organic reaction can be followed by IR spectroscopy. This is done by examining the IR spectra of portions of the reaction mixture withdrawn at certain time intervals. For example, in a reaction involving the oxidation of a secondary alcohol into a ketone, it is expected that the $\nu_{\text{O—H}}$ band near 3570 cm⁻¹ will disappear and a new $\nu_{\text{C=O}}$ band will appear near 1715 cm⁻¹ on completion of the reaction.

Besides the above applications, IR spectroscopy is often used to distinguish between *cis* and *trans* isomers (e.g. see Sections 3.8(iii) and 3.8(ix)), and between three, four, five and larger membered ring ketones (Section 3.8(ix)), lactones (Section 3.8(xi)) and lactams (Section 3.8(xiv)).

3.11 Interpretation of Infrared Spectra

There are no set rules for interpreting IR spectra. Organic chemists generally interpret IR spectra by inspecting and comparing the position, intensity and shape of bands with reference data available in tables of characteristic group frequencies. The presence or absence of an absorption band indicates the presence or absence of a particular functional group in a compound. For example, appearance of an absorption band near 3330 cm⁻¹ is indicative of an intermolecularly hydrogen bonded O—H group (Figs. 3.7 and 3.8). Similarly, appearance of a band around 1700 cm⁻¹ indicates the presence of a C=O group (Figs. 3.9 and 3.10). After tentative assignment of an absorption band to a particular group, it should be confirmed wherever possible by examination of other band(s) expected for that group. For example, the assignment of a carbonyl band to an aldehyde should be confirmed by the appearance of a band or a pair of bands in the region 2700–2900 cm⁻¹ due to aldehydic $\nu_{\text{C—H}}$ (Fig. 3.9). Similarly, the assignment of a carbonyl band to an ester should be confirmed by the presence of a strong band due to $\nu_{\text{C=O}}$ in the region 1000–1300 cm⁻¹ (Fig. 3.12).

The absence of characteristic absorption bands in the assigned regions for various functional groups shows the absence of such groups in the molecule. IR spectra of organic compounds are generally complex and it is not necessary from the interpretation point of view to assign each absorption band to a particular group. Usually, characteristic absorption bands of functional groups are used for their detection. It is rarely possible to deduce complete structure of a compound from its IR spectrum alone. In structure determination, IR spectroscopy is supplemented by chemical evidence and UV, NMR and mass spectral data.

The intensity and shape (or width) of bands are also important in the interpretation of IR spectra. For example, it would be wrong to pick out a weak band near 1700 cm⁻¹ and assign it to a $\nu_{\text{C=O}}$ in a spectrum of a pure compound because C=O and similar highly polar groups absorb strongly due to stretching vibrations. Broad bands are generally indicative of hydrogen bonding.

For easy interpretation of an IR spectrum, it may be divided into the following regions.

(i) 3200–3650 cm^{-1}

The appearance of medium to strong absorption bands in this region shows the presence of hydroxyl or amino groups. These bands arise from $\nu_{\text{O-H}}$ or $\nu_{\text{N-H}}$ vibrations. The position, intensity and width of the bands indicate whether the group is free or intermolecularly hydrogen bonded or intramolecularly hydrogen bonded. A medium band due to $\equiv\text{C-H}$ stretching also appears near 3300 cm^{-1} .

(ii) 3000–3200 cm^{-1}

Absorption bands due to $=\text{C-H}$ stretching and aromatic C-H stretching appear in this region. These bands are of medium intensity.

(iii) 2700–3000 cm^{-1}

In this region, usually a complex band or bands appear near 2850 cm^{-1} due to stretching vibrations of C-H bonds of saturated groups, i.e. $-\text{CH}_3$, $\begin{array}{c} \diagup \\ \text{CH}_2 \\ \diagdown \end{array}$ or $\begin{array}{c} \diagdown \\ \text{CH} \\ \diagup \end{array}$ (Fig. 3.4). The appearance of weak but sharp bands near $2700\text{--}2900 \text{ cm}^{-1}$ due to $\nu_{\text{C-H}}$ indicates the presence of aldehyde, methoxyl or N-methyl groups. A broad $\nu_{\text{O-H}}$ band present in the $2700\text{--}3000 \text{ cm}^{-1}$ region is characteristic of hydrogen-bonded $-\text{COOH}$ groups.

(iv) 2000–2700 cm^{-1}

Groups of the type $\text{X}=\text{Y}$, $\text{X}=\text{Y}=\text{X}$, etc. absorb in this region and exhibit bands of variable intensities. For example, bands due to $\text{C}\equiv\text{C}$ stretching appear in the region $2100\text{--}2260 \text{ cm}^{-1}$ and that due to $\text{C}\equiv\text{N}$ stretching appear in the region $2200\text{--}2260 \text{ cm}^{-1}$. Similarly, isocyanates absorb in the region $2240\text{--}2275 \text{ cm}^{-1}$ due to $\text{N}=\text{C}=\text{O}$ stretching. Besides these, $\nu_{\text{O-H}}$, $\nu_{\text{N-H}}$ and $\nu_{\text{S-H}}$ bands of carboxylic acid dimers, amine salts and thiols (or thiophenols), respectively also appear in this region ($2000\text{--}2700 \text{ cm}^{-1}$).

(v) 1600–1900 cm^{-1}

Strong absorption bands in the upper part of this region are due to $\text{C}=\text{O}$ stretching. Aldehydes, ketones, carboxylic acids, esters, amides, acid anhydrides, acyl halides, etc. absorb strongly in this region due to $\text{C}=\text{O}$ stretching. The position of $\nu_{\text{C}=\text{O}}$ band gives good indication of the nature of the attached groups and the molecular environment as summarized in the end of Section 3.8(xiv). Much weaker bands in the lower part of this region are often assignable to $\text{C}=\text{C}$ stretching of alkenes. $\nu_{\text{C}=\text{N}}$ and δNH_2 bands also occur in the lower part of this region.

The region $1800\text{--}2000 \text{ cm}^{-1}$ is often used for confirmation of the substitution pattern of a benzene nucleus but actually it is not useful because of weakness of these overtone bands ($2\gamma_{\text{C-H}}$ etc.).

(vi) 1000–1600 cm^{-1}

The most characteristic medium bands due to $\text{C}=\text{C}$ stretching in aromatic

compounds appear around 1600, 1580, 1500 and 1450 cm^{-1} (Fig. 3.6). The presence of aliphatic CH_2 and CH_3 groups is confirmed by the appearance of medium bands near 1450 cm^{-1} due to δCH_2 and δCH_3 , and near 1375 cm^{-1} due to δCH_3 only. If the compound contains geminal methyl groups, then the 1375 cm^{-1} band appears as a doublet. This region is useful for identification of nitro compounds and also for confirming the presence of ethers and esters, and primary, secondary and tertiary alcohols. For example, the appearance of a strong band due to $\nu_{\text{C=O}}$ between 1000 and 1300 cm^{-1} confirms the presence of an ester group provided $\nu_{\text{C=O}}$ band is present in the expected region, e.g. 1735–1750 cm^{-1} for saturated acyclic esters (Fig. 3.12).

(vii) 667–1000 cm^{-1}

This region is especially useful for the determination of orientations in aromatic compounds as discussed in Section 3.10(vi).

3.12 Some Solved Problems

Problem 1. How many bands due to fundamental vibrations do you expect to observe in the IR spectrum of water?

Solution. Water molecule is a nonlinear molecule, hence its vibrational degree of freedom, i.e. fundamental vibrations will be equal to $3n-6$ and can be calculated as follows:

Number of atoms (n) = 3

Total degrees of freedom ($3n$) = $3 \times 3 = 9$

Rotational degrees of freedom = 3

Translational degrees of freedom = 3

Hence, vibrational degrees of freedom ($3n - 6$) = $9 - 3 - 3 = 3$

Thus, there will be three fundamental modes of vibration. These are symmetrical stretching, asymmetrical stretching and bending vibrations. All these modes of vibrations are IR active and are non-degenerate. Thus, three absorption bands corresponding to these three fundamental modes of vibration are expected in the IR spectrum of water (the observed absorption bands occur at 3652, 3756 and 1595 cm^{-1}).

Problem 2. Using IR spectroscopy, how will you distinguish the following isomeric compounds:

- (i) $\text{CH}_3\text{CH}_2\text{C}\equiv\text{CH}$ and $\text{CH}_3\text{C}\equiv\text{CCH}_3$
- (ii) $\text{CH}_3\text{CH}_2\text{OH}$ and CH_3OCH_3
- (iii) $(\text{CH}_3)_3\text{N}$ and $\text{CH}_3\text{CH}_2\text{NHCH}_3$

Solution. (i) $\text{CH}_3\text{CH}_2\text{C}\equiv\text{CH}$ will show strong absorption bands at ~ 3300 , 2100 and 625 cm^{-1} due to $\equiv\text{C}-\text{H}$ stretching, $\text{C}\equiv\text{C}$ stretching and $\equiv\text{C}-\text{H}$ bending vibrations, respectively. All these bands will be absent in the IR spectrum of $\text{CH}_3\text{C}\equiv\text{CCH}_3$. It should be noted that $\nu_{\text{C=C}}$ band will also be absent in the IR spectrum of $\text{CH}_3\text{C}\equiv\text{CCH}_3$ because the symmetrical substitution makes the $\text{C}\equiv\text{C}$ stretching frequency IR inactive.

(ii) $\text{CH}_3\text{CH}_2\text{OH}$ will show absorption bands in the region $3200\text{--}3600\text{ cm}^{-1}$ due to stretching vibration of intermolecularly hydrogen-bonded O—H group and at $\sim 1050\text{ cm}^{-1}$ due to $\nu_{\text{C—O}}$. These bands will be absent in the IR spectrum of CH_3OCH_3 . It will show an absorption band around 1100 cm^{-1} due to C—O—C stretching.

(iii) $\text{CH}_3\text{CH}_2\text{NHCH}_3$ will show a medium band in the region $3310\text{--}3550\text{ cm}^{-1}$ due to N—H stretching. This band will be absent in IR spectrum of $(\text{CH}_3)_3\text{N}$.

Problem 3. How will you distinguish *o*-hydroxybenzaldehyde (salicylaldehyde) and *m*-hydroxybenzaldehyde on the basis of IR spectroscopy?

Solution. In salicylaldehyde, due to intramolecular hydrogen bonding, $\nu_{\text{O—H}}$ and $\nu_{\text{C=O}}$ bands are shifted to lower wavenumbers. Since it is intramolecular, change in concentration does not cause any shift in $\nu_{\text{O—H}}$ and $\nu_{\text{C=O}}$ absorption bands. In case of *m*-hydroxybenzaldehyde, $\nu_{\text{O—H}}$ and $\nu_{\text{C=O}}$ bands occur at a still lower wavenumber due to intermolecular hydrogen bonding. In this case, $\nu_{\text{O—H}}$ and $\nu_{\text{C=O}}$ bands shift to higher wavenumbers on dilution with a nonpolar solvent.

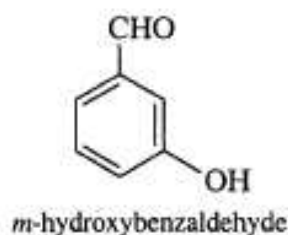
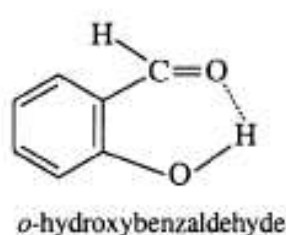

Problem 4. A hydrocarbon containing 10% hydrogen shows the following bands in its IR spectrum:

- (i) 3295 cm^{-1} (ii) 2130 cm^{-1} (iii) 625 cm^{-1}

Deduce the structure of the hydrocarbon.

Solution. Among various hydrocarbons, only alkynes show a band around 3300 cm^{-1} due to =C—H stretching. Thus, the appearance of a band at 3295 cm^{-1} clearly shows the presence of =C—H group in the hydrocarbon. The presence of a band at 2130 cm^{-1} due to $\text{C}\equiv\text{C}$ stretching and another band at 625 cm^{-1} due to =C—H bending confirm that the hydrocarbon is an alkyne. 10% hydrogen content shows that it is propyne ($\text{CH}_3\text{C}\equiv\text{CH}$).

Problem 5. Give suitable explanation for the following:

- (a) Stretching frequencies of C—C , C=C and $\text{C}\equiv\text{C}$ fall in the regions which are in increasing order $800\text{--}1200\text{ cm}^{-1}$, $1650\text{--}1670\text{ cm}^{-1}$ and $2100\text{--}2260\text{ cm}^{-1}$, respectively.

- (b) The $\nu_{\text{O-H}}$ band appears near 3570 cm^{-1} , whereas the $\nu_{\text{O-D}}$ band appears near 2630 cm^{-1} .
- (c) 2-*t*-butylphenol has two $\nu_{\text{O-H}}$ bands—one at 3608 cm^{-1} and the other at 3643 cm^{-1} , whereas 2,6-di-*t*-butylphenol has only one band at 3642 cm^{-1} .

Solution. (a) According to Hooke's law (Section 3.6, Eq. (3.1)), the stretching frequency of a bond increases with an increase in the force constant, i.e., bond strength. Thus, the stretching frequencies of carbon-carbon single, double and triple bonds increase in the order of their increasing bond strengths, i.e. the increasing order of stretching frequencies is



(b) According to Hooke's law (Section 3.6, Eq. (3.1)), the stretching frequency of a bond increases as the reduced mass of the bonded atoms decreases. Since hydrogen has lesser atomic mass than deuterium, the O—H stretching frequency (near 3570 cm^{-1}) is higher than the O—D stretching frequency (near 2630 cm^{-1}).

(c) In 2-*t*-butylphenol, two bands are present at 3608 and 3643 cm^{-1} showing that some molecules are intermolecularly hydrogen bonded, whereas in others OH is not hydrogen bonded due to steric hindrance by the bulky-*t*-butyl group.

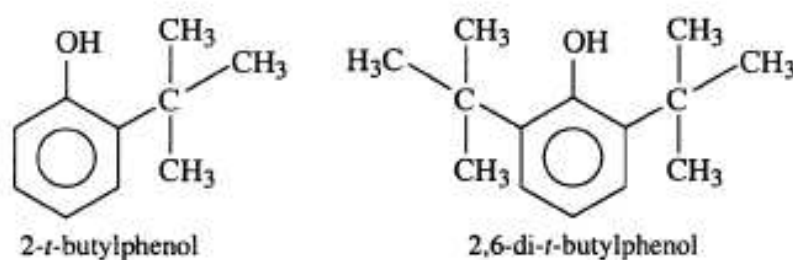

In 2,6-di-*t*-butylphenol, because of the presence of two bulky-*t*-butyl groups in the *ortho* position of the OH group, the OH groups of two different molecules are not able to approach close enough to form intermolecular hydrogen bond. Thus, 2,6-di-*t*-butylphenol shows only one $\nu_{\text{O-H}}$ band at 3642 cm^{-1} due to non-hydrogen-bonded OH group.

Problem 6. Giving reasons arrange the following compounds in order of decreasing frequency of carbonyl absorption in their IR spectra:

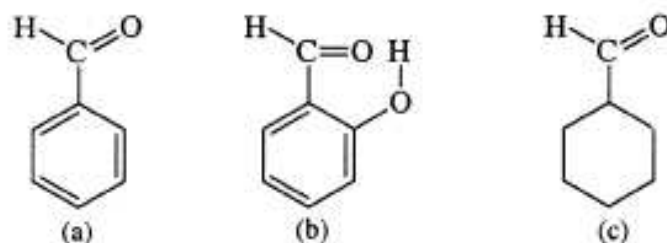

Solution. The following is decreasing order of frequency of carbonyl absorption

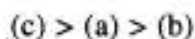

Cyclohexane carboxaldehyde (c) is a saturated aldehyde, hence will absorb around 1730 cm^{-1} . Due to conjugation of the $\text{C}=\text{O}$ group with the double bonds of the benzene ring, the $\nu_{\text{C}=\text{O}}$ absorption of benzaldehyde (a) will be shifted to lower frequency ($\sim 1700\text{ cm}^{-1}$). In salicylaldehyde (b), the lowering is due to conjugation as well as intramolecular hydrogen bonding (chelation), thus the $\nu_{\text{C}=\text{O}}$ absorption frequency is further lowered ($\sim 1665\text{ cm}^{-1}$).

Problem 7. How will you distinguish the two members of each of the following pairs of compound by their IR spectra:

- $\text{CH}_3\text{CH}_2\text{C}\equiv\text{CH}$ and $\text{CH}_3\text{CH}_2\text{C}\equiv\text{N}$
- RNH_2 and RCONH_2
- CH_3COCH_3 and $\text{CH}_3\text{CH}=\text{CHCH}_2\text{OH}$
- $\text{CH}_2=\text{CH}-\text{O}-\text{CH}_3$ and $\text{CH}_3\text{CH}_2\text{CHO}$
- $\text{CH}_3\text{CH}_2\text{CHO}$ and CH_3COCH_3

Solution. (a) $\text{CH}_3\text{CH}_2\text{C}\equiv\text{CH}$ will show strong absorption band at ~ 3300 and 625 cm^{-1} due to $\equiv\text{C}-\text{H}$ stretching and bending vibrations, respectively. These bands will be absent in the IR spectrum of $\text{CH}_3\text{CH}_2\text{C}\equiv\text{N}$.

(b) RCONH_2 will show a strong $\nu_{\text{C}=\text{O}}$ band around 1690 cm^{-1} (in dilute solution) which will be absent in the IR spectrum of RNH_2 .

(c) CH_3COCH_3 will show a strong $\nu_{\text{C}=\text{O}}$ band at $\sim 1715\text{ cm}^{-1}$. This band will be absent in $\text{CH}_3\text{CH}=\text{CHCH}_2\text{OH}$. Compound $\text{CH}_3\text{CH}=\text{CHCH}_2\text{OH}$ will show a strong $\nu_{\text{O}-\text{H}}$ band in the region $3200-3650\text{ cm}^{-1}$ and another medium $\nu_{\text{C}=\text{C}}$ band in the region $1620-1680\text{ cm}^{-1}$.

(d) $\text{CH}_3\text{CH}_2\text{CHO}$ will show a strong $\nu_{\text{C}=\text{O}}$ band near 1730 cm^{-1} and another weak band (generally appearing as a doublet due to Fermi resonance) in the region $2700-2900\text{ cm}^{-1}$ due to aldehydic $\nu_{\text{C}-\text{H}}$. $\text{CH}_2=\text{CH}-\text{O}-\text{CH}_3$ will show a strong band in the range $1020-1075\text{ cm}^{-1}$ due to $\text{C}-\text{O}-\text{C}$ stretching and another medium band near 1650 cm^{-1} due to $\text{C}=\text{C}$ stretching.

(e) Acetone will show a strong $\nu_{\text{C}=\text{O}}$ band at $\sim 1715\text{ cm}^{-1}$, whereas this band appears at $\sim 1730\text{ cm}^{-1}$ in propionaldehyde. In addition, $\text{CH}_3\text{CH}_2\text{CHO}$ will show a band in the range $2700-2900\text{ cm}^{-1}$ due to aldehydic $\text{C}-\text{H}$ stretching. This band generally appears as a doublet due to Fermi resonance.

Problem 8. How will you distinguish maleic acid and fumaric acid by their IR spectra.

Solution

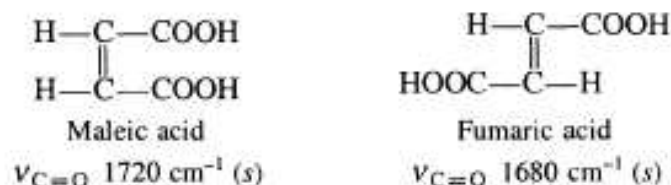

In maleic acid, the bulky COOH groups are on the same side of the double bond, hence due to repulsive interactions the $\text{C}=\text{O}$ group is forced out of the

plane of the C=C bond. Thus, the conjugation is diminished resulting in the appearance of $\nu_{\text{C=O}}$ band at a higher frequency as compared to that in fumaric acid where the C=O group is in conjugation with the C=C bond.

Problem 9. A compound having molecular formula $\text{C}_3\text{H}_6\text{O}$ gave the following spectral data:

- (i) UV: λ_{max} 292 nm, ϵ_{max} 21
- (ii) IR: 2720 cm^{-1} (w) and 1738 cm^{-1} (s)

Deduce the structure of the compound.

Solution. The compound shows λ_{max} 292 nm with ϵ_{max} 21 indicating that it is either an aldehyde or ketone and this band has arisen from $n \rightarrow \pi^*$ transition of its C=O group. The appearance of a strong IR absorption band at 1738 cm^{-1} is indicative of an aldehydic carbonyl group which is confirmed by the presence of another band at 2720 cm^{-1} due to aldehydic C—H stretching. Thus, the compound is $\text{CH}_3\text{CH}_2\text{CHO}$.

Problem 10. Fig. 3.16 shows the IR spectrum of a compound having molecular formula $\text{C}_8\text{H}_8\text{O}$. Interpret the spectrum and deduce the structure of the compound.

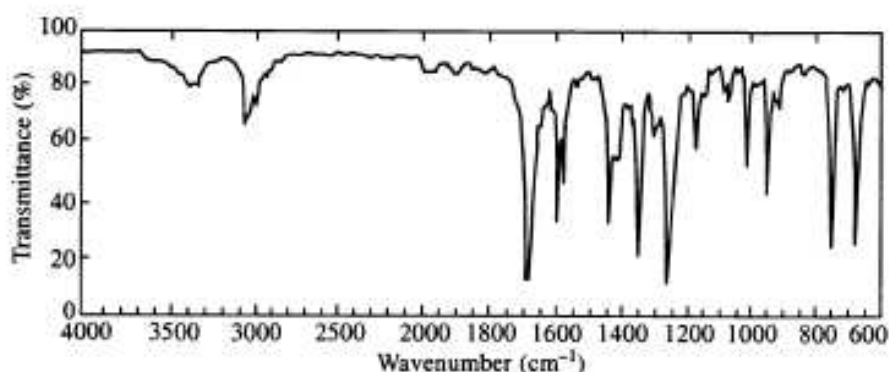

Fig. 3.16

Solution. The compound shows an absorption around 3010 cm^{-1} indicating the presence of a =C—H group. The presence of a phenyl nucleus is shown by the absorption bands at 1600 , 1580 and 1450 cm^{-1} . The appearance of out-of-plane bending absorptions at 762 and 692 cm^{-1} indicates a monosubstituted benzene ring.

The presence of the 1580 cm^{-1} band indicates the presence of a substituent which can conjugate with the phenyl nucleus. The appearance of a strong band at 1690 cm^{-1} shows that the compound is an aromatic ketone. It cannot be an acid because it contains only one oxygen atom; its molecular formula is $\text{C}_8\text{H}_8\text{O}$. Thus, the compound is acetophenone.

PROBLEMS

1. (a) In terms of transitions, how does IR spectroscopy differ from UV spectroscopy?
- (b) Arrange the following transitions in order of their increasing energy requirement:

Vibrational, electronic and rotational

2. Write notes on:
 - (a) Stretching and bending vibrations
 - (b) Fingerprint region
 - (c) Fermi resonance
3. Comment on the following:
 - (a) Hydrogen bonding raises the wavelength of IR absorption.
 - (b) Ethanol and methanol are good solvents for recording UV spectra but not for IR spectra.
 - (c) $\nu_{C=O}$ frequency for ethyl acrylate is lower than that for ethyl propionate. (Hint. Due to conjugation.)
4. Calculate the number of fundamental vibrations in the following molecules:
 - (i) Methane (ii) Ethanol (iii) Acetylene (iv) Ethylene (v) Oxygen
5. Assign the following IR absorption bands to a particular carboxylic acid derivative in each case:
 - (i) 1715–1750 cm^{-1} (ii) 1750–1815 cm^{-1} (iii) 1630–1690 cm^{-1}
 - (iv) 1740–1790 and 1800–1850 (two bands)
6. Explain the following:
 - (a) Concentrated solutions of alcohols in CCl_4 have an IR absorption band at about 3300 cm^{-1} but this band is shifted to a higher frequency on dilution.
 - (b) IR spectra have a large number of absorption bands as compared to UV spectra. (Hint. Due to large number of stretching and bending vibrations in the molecule.)
 - (c) *o*-Nitrophenol shows ν_{O-H} band at 3200 cm^{-1} in KBr pellet as well as in CHCl_3 solution, whereas the *para* isomer shows this band at different frequencies in the two media (in pellet at 3330 cm^{-1} and in CHCl_3 solution at 3520 cm^{-1} .) (Hint. The O—H group of *o*-nitrophenol is intramolecularly hydrogen bonded. Hence its frequency is not affected by the medium or change of concentration, whereas the *para* isomer is intermolecularly hydrogen-bonded in pellet and the hydrogen bonding diminishes in CHCl_3 solution due to relative dilution resulting in the shift of ν_{O-H} band to higher frequency, 3520 cm^{-1} .)
7. How will you distinguish the two members of each of the following pairs of compounds using IR spectroscopy:
 - (a) CH_3COOH and HCOOCH_3
 - (b) β -propiolactone and γ -butyrolactone
 - (c) $\text{ClCH}_2\text{CH}_2\text{CH}_2\text{COOH}$ and $\text{CH}_3\text{OCH}_2\text{CH}_2\text{COCl}$
 - (d) $\text{CH}_3\text{CH}_2\text{CHO}$ and $\text{CH}_2=\text{CH}-\text{CH}_2\text{OH}$
8. How can IR and UV spectroscopy be used to determine when the following reaction is completed?

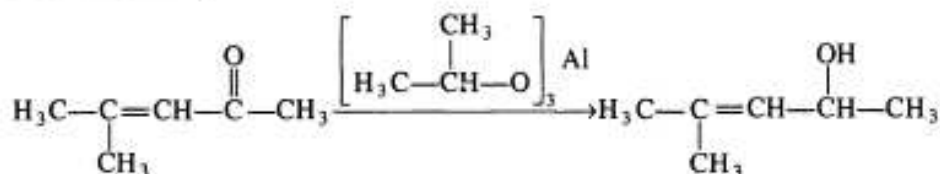

(Hint. The UV spectrum of the starting material will show λ_{max} at 237 and 310 nm due to conjugated C=C and C=O groups respectively. These bands will disappear on completion of the reaction. Similarly, the IR absorption band in the region 1665–1685 cm^{-1} due to conjugated C=O group (present in the starting material) will disappear on completion of the reaction. In addition, a new IR absorption band will appear around 3330 cm^{-1} due to hydrogen-bonded O—H group.)

9. Giving reasons arrange the following compounds in order of increasing wavenumber of carbonyl absorption in their IR spectra:
 - (a) Acetophenone, *p*-nitroacetophenone and *p*-aminoacetophenone. (Hint. A group with +*M* effect will decrease and that with –*M* effect will increase the bond order of C=O bond.)
 - (b) Cyclobutanone, cyclohexanone and cyclopentanone.
10. Discuss the factors which affect the IR absorption frequency of a functional group.
11. Explain why esters of *o*-chlorobenzoic acid show two C=O stretching absorptions?

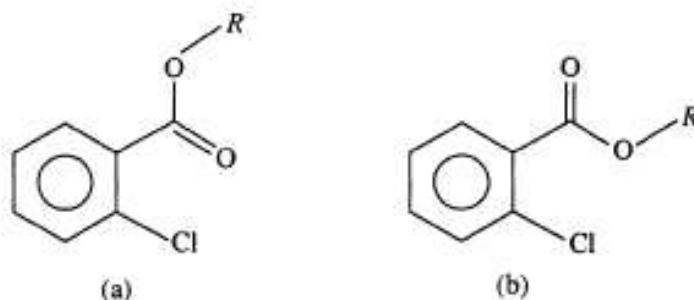

(Hint. In the rotational isomer (a) of *o*-chlorobenzoic ester, Cl is near the C=O group and its negative field repels the non-bonding electrons of the carbonyl oxygen (field effect). Thus, the force constant of C=O bond is increased resulting in shifting of the $\nu_{\text{C=O}}$ band to a higher frequency. Such shift does not occur in the isomer (b). Normally, both the isomers are present, thus two $\nu_{\text{C=O}}$ absorptions are observed.)

12. Deduce the structures of isomeric compounds (A) and (B) having molecular formula $\text{C}_3\text{H}_6\text{O}$ and the following IR spectral data:
(A) 1710 cm^{-1} (B) 3300 cm^{-1} and 1640 cm^{-1}
13. How will you distinguish the following pairs of compounds on the basis of IR spectroscopy?
 - (a) $\text{CH}_3\text{CH}_2\text{COCl}$ and $\text{ClCH}_2\text{COCH}_3$
 - (b) β -propiolactam and γ -butyrolactam
 - (c) Benzene and cyclohexane
 - (d) Salicylic acid and *m*-hydroxybenzoic acid
14. Which of the following compounds do you expect to have higher $\nu_{\text{O—H}}$ frequency in dil. CHCl_3 solution and why?

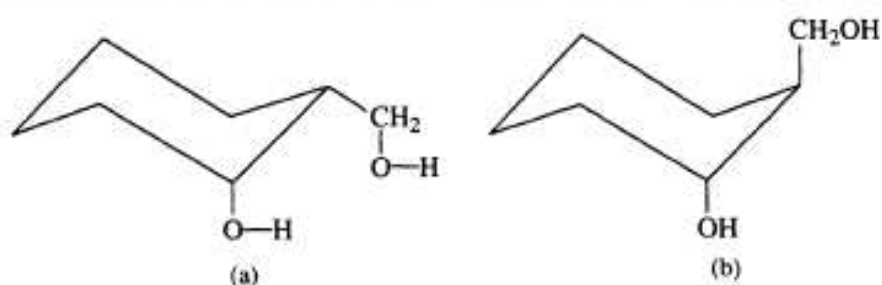

(Hint. In (a) intramolecular hydrogen bonding will decrease $\nu_{\text{O-H}}$ frequency.)

15. Giving reasons arrange the following compounds in order of increasing wavelength of carbonyl absorption in their IR spectra:

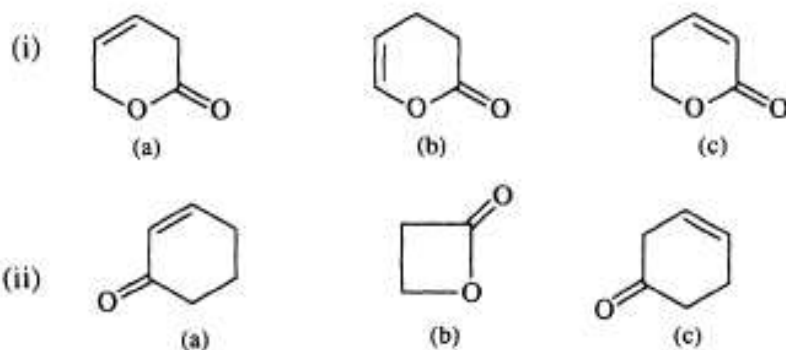

16. An organic compound (A) having molecular formula $\text{C}_3\text{H}_7\text{NO}$ shows IR absorption bands at 3413 (*m*), 3236 (*m*), 2899–3030 (*m*), 1667 (*s*), 1634 (*s*) and 1460 cm^{-1} (*s*). Give the probable structure of (A).
17. Giving examples discuss how inductive and mesomeric effects influence the carbonyl absorption frequency?
18. Explain why a compound in the vapour state has higher stretching frequency than that in the liquid or solid state? (Hint. Due to intermolecular interactions, especially when polar groups capable of hydrogen bonding are present, the force constants of bonds are decreased.)
19. Giving reasons arrange the following in increasing order of their $\nu_{\text{O-H}}$ frequency: ethanol, trichloroacetic acid, acetic acid and chloroacetic acid.
20. The IR spectrum of methyl salicylate shows absorption bands at 3300, 3050, 2990, 1700, 1590 and 1540 cm^{-1} . Which of these bands are due to which of the following groups?

$\text{C}=\text{O}$, CH_3 , $\text{O}-\text{H}$ and aromatic ring

21. Fig. P3.1 shows the IR spectrum of a pure liquid (A) which is easily oxidized by alkaline KMnO_4 into a carboxylic acid. Deduce the structure of (A).

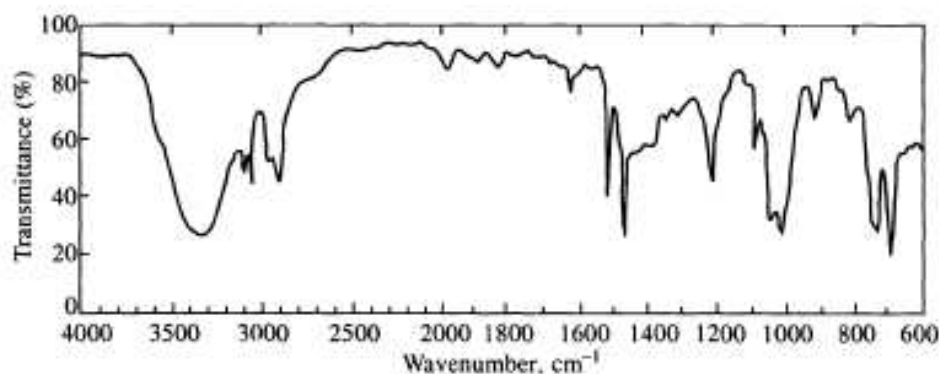

Fig. P3.1

22. Fig. P3.2 shows the IR spectrum of a neat liquid with molecular formula C_2H_6O . Assign its structure.

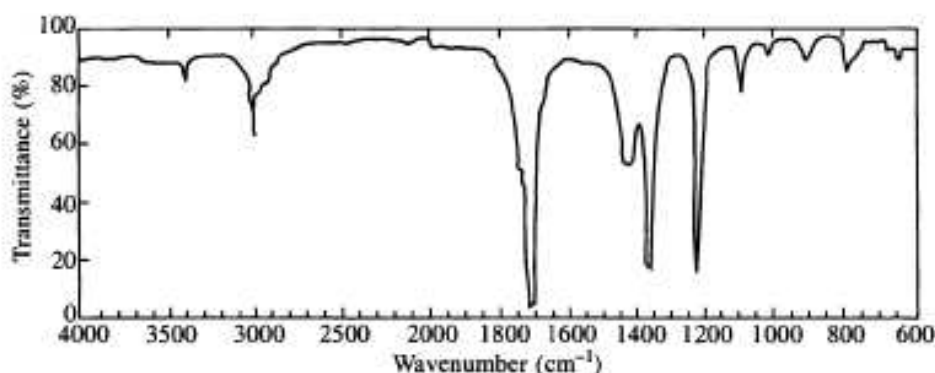

Fig. P3.2

23. Ethyl acetate shows $\nu_{C=O}$ absorption at 1735 cm^{-1} , whereas phenyl acetate at 1770 cm^{-1} . Explain.
24. Arrange the following compounds in order of increasing absorption frequency of their carbonyl groups. Give reason for your answer.



25. Using IR spectroscopy, how will you distinguish:
- Intermolecular and intramolecular hydrogen bonding
 - cis*-cinnamic acid and *trans*-cinnamic acid
 - Axial and equatorial O—H group. (Hint. Due to 1,3-diaxial interaction, the stretching vibration of the axial O—H group is hindered and thus its absorption frequency is raised.)
26. Indicate which of the following vibrations will be IR active or inactive?

Molecule	Mode of vibration
(i) $CH_2=CH_2$	$C=C$ stretching
(ii) $CH_2=CH_2$	$C-H$ stretching
(iii) N_2	$N\equiv N$ stretching
(iv) SO_2	Symmetrical stretching
(v) CO_2	Symmetrical stretching
(vi) CH_3-CH_3	$C-C$ stretching

27. 2-hydroxy-3-nitroacetophenone shows two $\nu_{C=O}$ bands at 1692 and 1658 cm^{-1} . Explain.
(Hint. In some molecules, there is intramolecular hydrogen bonding between OH and $C=O$, while in other between OH and NO_2 group.)
28. IR spectrum of a neat liquid with molecular formula C_4H_8O is given in Fig. P3.3. Interpret the spectrum and assign the structure to the compound.

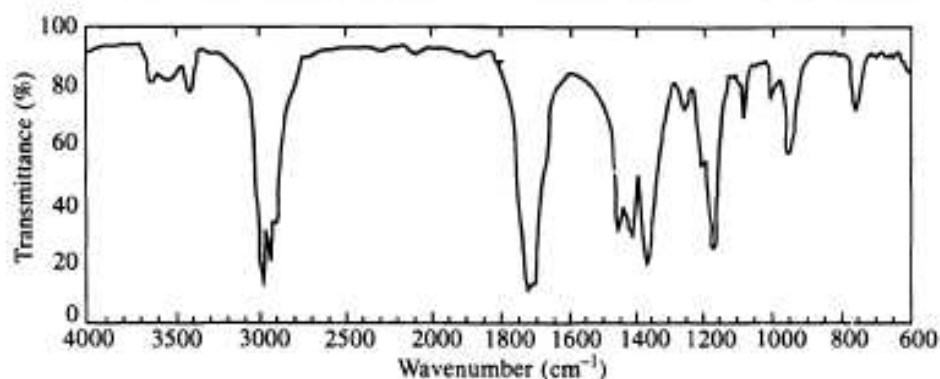

Fig. P3.3

29. Explain why $\nu_{\text{C=O}}$ frequency for *m*-chlorobenzoic acid is higher than that for *p*-chlorobenzoic acid? (Hint. Due to +*M* effect, Cl decreases the force constant of C=O bond from the *para* position but not from the *meta* position.)
30. A compound with molecular formula $\text{C}_7\text{H}_8\text{O}$ gives the following IR spectral data. Deduce the structure of the compound.
IR bands at ~ 3300 (*s*), ~ 3040 (*m*), 2800–2950 (*w*), 1606 (*m*), 1582 (*m*), 1500 (*m*), 1450 (*w*), 1380 (*w*), 1185 (*s*), 780 (*s*) and 692 cm^{-1} (*s*).
31. IR spectrum of a neat liquid with molecular formula $\text{C}_7\text{H}_6\text{O}$ is given in Fig. P3.4. Interpret the spectrum and assign the structure to the compound.

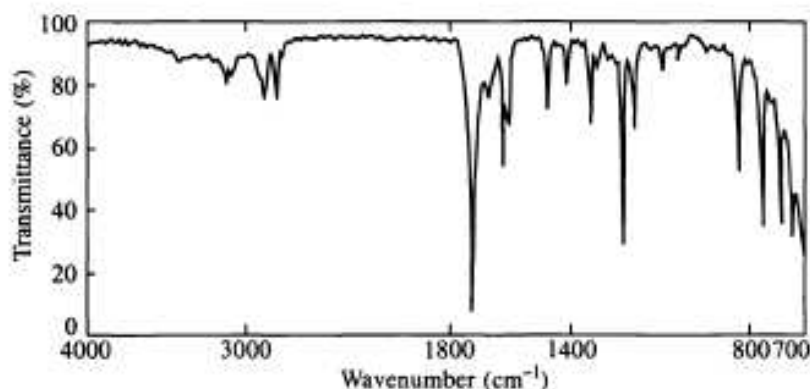

Fig. P3.4

References

1. A.D. Cross, Introduction to Practical Infrared Spectroscopy, 3rd Ed., Butterworth, London, 1969.
2. C.N.R. Rao, Chemical Application of Infrared Spectroscopy, Academic Press, New York and London, 1963.
3. D.H. Williams and I. Fleming, Spectroscopic Methods in Organic Chemistry, McGraw-Hill, London, 1966.
4. F. Schienmann, Ed., An Introduction to Spectroscopic Methods for the Identification of Organic Compounds, Vol. 1, Pergamon Press, Oxford, 1970.
5. H.A. Szymanski, Correlation of Infrared and Raman Spectra of Organic Compounds, Hertilon Press, 1969.
6. J.M. van der Mass, Basic Infrared Spectroscopy, Heyden, London, 1969.

7. J.R. Dyer, *Applications of Absorption Spectroscopy of Organic Compounds*, Prentice-Hall, Englewood Cliffs, N.J., 1965.
8. K. Nakanishi and P.H. Solomon, *Infrared Absorption Spectroscopy—Practical*, 2nd Ed., San Francisco, Holden-Day, 1977.
9. L.J. Bellamy, *The Infrared Spectra of Complex Organic Molecules*, Methuen, London, Vol. 1, 3rd Ed., 1975; Vol. 2, 1980.
10. N.B. Colthup, L.H. Daly and S.E. Wiberley, *Introduction to infrared and Raman Spectroscopy*, 3rd Ed., Academic Press, New York and London, 1990.
11. R.M. Silverstein, G.C. Bassler and T.C. Morrill, *Spectrometric Identification of Organic Compounds*, 3rd Ed., Wiley, New York, 1974.
12. R.T. Conley, *Infrared Spectroscopy*, 2nd Ed., Allyn and Bacon, Boston, 1972.
13. S. Sternhell and J.R. Kalman, *Organic Structures from Spectra*, Wiley, Chichester, 1986.