

e) Energy resources

Energy is defined by physicists as the capacity to do work. Energy is found on our planet in a variety of forms, some of which are immediately useful to do work, while others require a process of transformation.

The sun is the primary energy source in our lives. We use it directly for its warmth and through various natural processes that provide us with food, water, fuel and shelter. The sun's rays power the growth of plants, which form our food material, give off oxygen which we breathe in and take up carbon dioxide that we breathe out. Energy from the sun evaporates water from oceans, rivers and lakes, to form clouds that turn into rain. Today's fossil fuels were once the forests that grew in prehistoric times due to the energy of the sun.

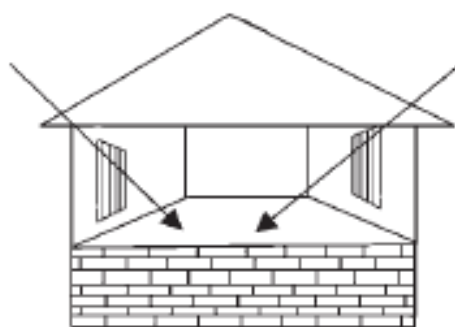

Chemical energy, contained in chemical compounds is released when they are broken down by animals in the presence of oxygen. In India, manual labour is still extensively used to get work done in agricultural systems, and domestic animals used to pull carts and ploughs. Electrical energy produced in several ways, powers transport, artificial lighting, agriculture and industry. This comes from hydel power based on the water cycle that is powered by the sun's energy that supports evaporation, or from thermal power stations powered by fossil fuels. Nuclear energy is held in the nucleus of an atom and is now harnessed to develop electrical energy.

We use energy for household use, agriculture, production of industrial goods and for running transport. Modern agriculture uses chemical fertilizers, which require large amounts of energy during their manufacture. Industry uses energy to power manufacturing units and the urban complexes that support it. Energy-demanding roads and railway lines are built to transport products from place to place and to reach raw materials in mines and forests.

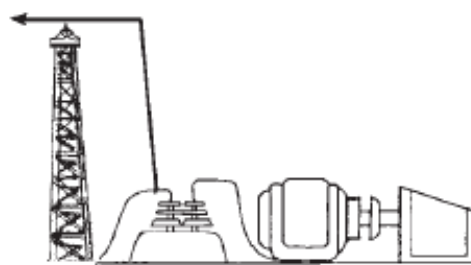

No energy related technology is completely 'risk free' and unlimited demands on energy increase this risk factor many fold. All energy use creates heat and contributes to atmospheric temperature. Many forms of energy release carbon dioxide and lead to global warming.

Nuclear energy plants have caused enormous losses to the environment due to the leakage of nuclear material. The inability to effectively manage and safely dispose of nuclear waste is a serious global concern.

At present almost 2 billion people worldwide have no access to electricity at all. While more people will require electrical energy, those who do have access to it continue to increase their individual requirements. In addition, a large proportion of energy from electricity is wasted during transmission as well as at the user level. It is broadly accepted that long-term trends in energy use should be towards a cleaner global energy system that is less carbon intensive and less reliant on finite non-renewable energy sources. It is estimated that the currently used methods of using renewable energy and non renewable fossil fuel sources together will be insufficient to meet foreseeable global demands for power generation beyond the next 50 to 100 years.

Thus when we use energy wastefully, we are contributing to a major environmental disaster for our earth. We all need to become responsible energy users. An electrical light that is burning unnecessarily is a contributor to environmental degradation.

Growing energy needs: Energy has always been closely linked to man's economic growth and development. Present strategies for development that have focused on rapid economic growth have used energy utilization as an index of economic development. This index however, does not take into account the long-term ill effects on society of excessive energy utilisation.

In 1998, the World Resources Institute found that the average American uses 24 times the energy used by an Indian.
--

Between 1950 and 1990, the world's energy needs increased four fold. The world's demand for electricity has doubled over the last 22 years! The world's total primary energy consumption in 2000 was 9096 million tons of oil. A global average per capita that works out to be 1.5 tons oil. Electricity is at present the fastest growing form of end-use energy worldwide. By 2005 the Asia-Pacific region is expected to surpass North America in energy consumption and by 2020 is expected to consume some 40% more energy than North America.

For almost 200 years, coal was the primary energy source fuelling the industrial revolution in the 19th century. At the close of the 20th century, oil accounted for 39% of the world's commercial energy consumption, followed by coal (24%) and natural gas (24%), while nuclear (7%) and hydro/renewables (6%) accounted for the rest.

Among the commercial energy sources used in India, coal is a predominant source accounting for 55% of energy consumption estimated in 2001, followed by oil (31%), natural gas (8%), hydro (5%) and nuclear (1%).

In India, biomass (mainly wood and dung) accounts for almost 40% of primary energy supply. While coal continues to remain the dominant fuel for electricity generation, nuclear power has been increasingly used since the 1970s and 1980s and the use of natural gas has increased rapidly in the 80s and 90s.

Types of energy: There are three main types of energy; those classified as **non-renewable**; those that are said to be **renewable**; and **nuclear energy**, which uses such small quantities of

raw material (uranium) that supplies are to all effect, limitless. However, this classification is inaccurate because several of the renewable sources, if not used 'sustainably', can be depleted more quickly than they can be renewed.

Non renewable energy

To produce electricity from non-renewable resources the material must be ignited. The fuel is placed in a well contained area and set on fire. The heat generated turns water to steam, which moves through pipes, to turn the blades of a turbine. This converts magnetism into electricity, which we use in various appliances.

Non-Renewable Energy Sources: These consist of the mineral based hydrocarbon fuels coal, oil and natural gas, that were formed from ancient prehistoric forests. These are called 'fossil fuels' because they are formed after plant life is fossilized. At the present rate of extraction there is enough coal for a long time to come. Oil and gas resources however are likely to be used up within the next 50 years. When these fuels are burnt, they produce waste products that are released into the atmosphere as gases such as carbon dioxide, oxides of sulphur, nitrogen, and carbon monoxide, all causes of air pollution. These have led to lung problems in an enormous number of people all over the world, and have also affected buildings like the Taj Mahal and killed many forests and lakes due to acid rain. Many of these gases also act like a green house letting sunlight in and trapping the heat inside. This is leading to global warming, a raise in global temperature, increased drought in some areas, floods in other regions, the melting of icecaps, and a rise in sea levels, which is slowly submerging coastal belts all over the world. Warming the seas also leads to the death of sensitive organisms such as coral.

Oil and its environmental impacts: India's oil reserves which are being used at present lie off the coast of Mumbai and in Assam. Most of our natural gas is linked to oil and, because there is no distribution system, it is just burnt off. This wastes nearly 40% of available gas. The processes of oil and natural gas drilling, processing, transport and utilisation have serious environmental consequences, such as leaks in which air and water are polluted and accidental fires that may go on burning for days or weeks before the fire can be controlled. During refining oil, solid waste such as salts and grease are produced which also damage the environment. Oil slicks are caused at sea from offshore oil wells, cleaning of oil tankers and due to shipwrecks. The most well-known disaster occurred when the Exxon Valdez sank in 1989 and birds, sea otters, seals, fish and other marine life along the coast of Alaska was seriously affected.

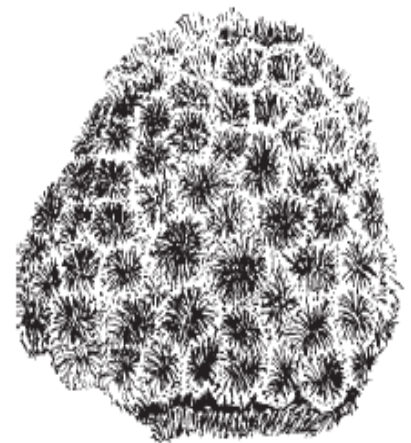

Oil powered vehicles emit carbon dioxide, sulphur dioxide, nitrous oxide, carbon monoxide and particulate matter which is a major cause of air pollution especially in cities with heavy traffic density. Leaded petrol, leads to neuro damage and reduces attention spans. Running petrol vehicles with unleaded fuel has been achieved by adding catalytic converters on all the new cars, but unleaded fuel contains benzene and butadene which are known to be carcinogenic compounds. Delhi, which used to have serious smog problems due to traffic, has

been able to reduce this health hazard by changing a large number of its vehicles to CNG, which contains methane.

Dependence on dwindling fossil fuel resources, especially oil, results in political tension, instability and war. At present 65 percent of the world's oil reserves are located in the Middle East.

Coal and its environmental impacts: Coal is the world's single largest contributor of green house gases and is one of the most important causes of global warming.

Many coal-based power generation plants are not fitted with devices such as electrostatic precipitators to reduce emissions of suspended particulate matter (SPM) which is a major contributor to air pollution. Burning coal also produces oxides of sulphur and nitrogen which, combined with water vapour, lead to 'acid rain'. This kills forest vegetation, and damages architectural heritage sites, pollutes water and affects human health.

Thermal power stations that use coal produce waste in the form of 'fly ash'. Large dumps are required to dispose off this waste material, while efforts have been made to use it for making bricks. The transport of large quantities of fly ash and its eventual dumping are costs that have to be included in calculating the cost-benefits of thermal power.

CASE STUDY

The Exxon Valdez was wrecked in Prince William Sound in Alaska in 1989 and polluted large parts of the surrounding seas.

CASE STUDY

Oil related disasters

During the Gulf War, oil installations burned for weeks polluting the air with poisonous gasses. The fires wasted 5 million barrels of oil and produced over a million tons of airborne pollutants, including sulphur dioxide, a major cause of acid rain. The gases moved to a height of 3km and spread as far as India. Oil also polluted coastlines, killing birds and fish.

Renewable energy

Renewable energy systems use resources that are constantly replaced and are usually less polluting. Examples include hydropower, solar, wind, and geothermal (energy from the heat inside the earth). We also get renewable energy from burning trees and even garbage as fuel and processing other plants into biofuels.

One day, all our homes may get their energy from the sun or the wind. Your car's gas tank will use biofuel. Your garbage might contribute to your city's energy supply. Renewable energy technologies will improve the efficiency and cost of energy systems. We may reach the point when we may no longer rely mostly on fossil fuel energy.

CASE STUDY

Nearly 50% of the world's population is dependent on fuel wood as a source of energy. This is obvious in our own country, which has lost a large proportion of its forest cover as our population expands and burns enormous amounts of wood. Rural women, and even women

from the lower economic strata in towns, still have to spend a large part of their lives collecting fuel wood. To overcome this, various types of fuel-efficient stoves ('chulas') can burn wood extremely slowly and do not waste the heat, and also produce less smoke and ash than normal 'chulas'. There have also been several efforts to grow fuelwood by involving local people in these efforts. Examples include Social Forestry, Farm Forestry and Joint Forestry Management.

Hydroelectric Power

This uses water flowing down a natural gradient to turn turbines to generate electricity known as 'hydroelectric power' by constructing dams across rivers. Between 1950 and 1970, Hydropower generation worldwide increased seven times. The long life of hydropower plants, the renewable nature of the energy source, very low operating and maintenance costs, and absence of inflationary pressures as in fossil fuels, are some of its advantages.

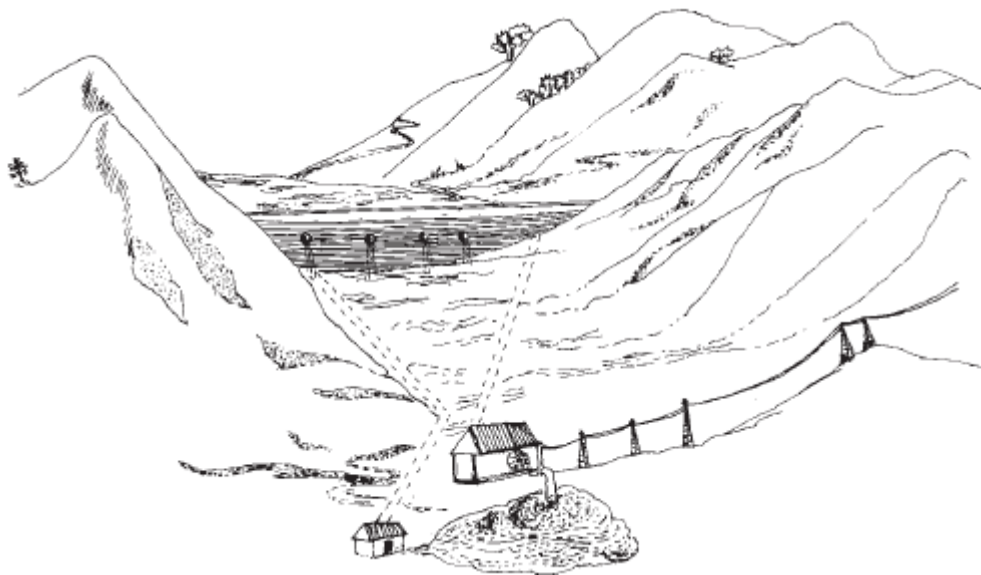

CASE STUDY

In 1882, the first Hydroelectric power dam was built in Appleton, Wisconsin. In India the first hydroelectric power dams were built in the late 1800s and early 1900s by the Tatas in the Western Ghats of Maharashtra. Jamshedjee Tata, a great visionary who developed industry in India in the 1800s, wished to have a clean source of energy to run cotton and textile mills in Bombay as he found people were getting respiratory infections due to coal driven mills. He thus asked the British Government to permit him to develop dams in the Western Ghats to generate electricity. The four dams are the Andhra, Shirowata, Valvan and Mulshi hydel dams. An important feature of the Tata power projects is that they use the high rainfall in the hills as storage areas. While the rivers flowing eastwards from the Western Ghats are dammed in the foothills near the Deccan plateau, the water is tunneled through the crest of the Ghats to drop several hundred meters to the coastal belt. Large turbines in the power plants generate electricity for Mumbai and its giant industrial belt.

Drawbacks: Although hydroelectric power has led to economic progress around the world, it has created serious ecological problems.

- To produce hydroelectric power, large areas of forest and agricultural lands are submerged. These lands traditionally provided a livelihood for local tribal people and farmers. Conflicts over land use are inevitable.
- Silting of the reservoirs (especially as a result of deforestation) reduces the life of the hydroelectric power installations.
- Water is required for many other purposes besides power generation. These include domestic requirements, growing agricultural crops and for industry. This gives rise to conflicts.
- The use of rivers for navigation and fisheries becomes difficult once the water is dammed for generation of electricity.
- Resettlement of displaced persons is a problem for which there is no ready solution. The opposition to many large hydroelectric schemes is growing as most dam projects have been unable to resettle people that were affected and displaced.
- In certain regions large dams can induce seismic activity which will result in earthquakes. There is a great possibility of this occurring around the Tehri dam in the Himalayan foothills. Shri Sunderlal Bahuguna, the initiator of the Chipko Movement has fought against the Tehri Dam for several years.

CASE STUDY

Narmada Project

The Narmada Bachao Andolan in India is an example of a movement against large dams. The gigantic Narmada River Project has affected the livelihoods of hundreds of extremely poor forest dwellers. The rich landholders downstream from the Sardar Sarovar dam will derive the maximum economic benefit, whereas the poor tribal people have lost their homes and traditional way of life. The dam will also destroy the livelihood of fishermen at the estuary. The disastrous impact that this project has on the lives of the poor, and the way in which they are being exploited, need to be clearly understood.

With large dams causing social problems, there has been a trend to develop small hydroelectric generation units. Multiple small dams have less impact on the environment. China has the largest number of these - 60,000, generating 13,250 megawatts, i.e. 30% of China's electricity. Sweden, the US, Italy and France also have developed small dams for electrical power generation. The development of small hydroelectric power units could become a very important resource in India, which has steeply falling rivers and the economic capability and technical resources to exploit them.

Solar energy: In one hour, the sun pours as much energy onto the earth as we use in a whole year. If it were possible to harness this colossal quantum of energy, humanity would need no other source of energy. Today we have developed several methods of collecting this energy for heating water and generating electricity.

Solar heating for homes: Modern housing that uses air conditioning and/ or heating are extremely energy dependant. A passive solar home or building is designed to collect the sun's heat through large, south-facing glass windows. In solar heated buildings, sunspaces are built on the south side of the structure which act as large heat absorbers. The floors of sunspaces are usually made of tiles or bricks that absorb heat throughout the day, then release heat at night when its cold.

In energy efficient architecture the sun, water and wind are used to heat a building when the weather is cold and to cool it in summer. This is based on design and building material. Thick walls of stone or mud were used in traditional architecture as an insulator. Small doors and windows kept direct sunlight and heat out. Deeply set glass windows in colonial homes, on which direct sunlight could not reach, permitted the glass from creating a green house effect. Verandahs also served a similar purpose.

Traditional bungalows had high roofs and ventilators that permitted hot air to rise and leave the room. Cross ventilation where wind can drive the air in and out of a room keeps it cool. Large overhangs over windows prevent the glass from heating the room inside. Double walls are used to prevent heating. Shady trees around the house help reduce temperature.

Solar water heating: Most solar water-heating systems have two main parts: the solar collector and the storage tank. The solar energy collector heats the water, which then flows to a well insulated storage tank.

A common type of collector is the flat-plate collector, a rectangular box with a transparent cover that faces the sun, usually mounted on the roof. Small tubes run through the box, carrying the water or other fluid, such as antifreeze, to be heated. The tubes are mounted on a metal absorber plate, which is painted black to absorb the sun's heat. The back and sides of the box are insulated to hold in the heat. Heat builds up in the collector, and as the fluid passes through the tubes, it too heats up.

Solar water-heating systems cannot heat water when the sun is not shining. Thus homes must also have a conventional backup system. About 80% of homes in Israel have solar hot water heaters.

Solar cookers: The heat produced by the sun can be directly used for cooking using solar cookers. A solar cooker is a metal box which is black on the inside to absorb and retain heat. The lid has a reflective surface to reflect the heat from the sun into the box. The box contains black vessels in which the food to be cooked is placed.

India has the world's largest solar cooker program and an estimated 2 lakh families that use solar cookers. Although solar cookers reduce the need for fuel wood and pollution from smoky wood fires, they have not caught on well in rural areas as they are not suitable to traditional cooking practices. However, they have great potential if marketed well.

Other Solar-Powered Devices: Solar desalination systems (for converting saline or brackish water into pure distilled water) have been developed. In future, they should become important alternatives for man's future economic growth in areas where fresh water is not available.

Photovoltaic energy: The solar technology which has the greatest potential for use throughout the world is that of solar photo voltaic cells which directly produce electricity from sunlight using photovoltaic (PV) (also called solar) cells. Solar cells use the sun's light, not its heat, to make electricity. PV cells require little maintenance, have no moving parts, and essentially no environmental impact.

Photovoltaic Cells

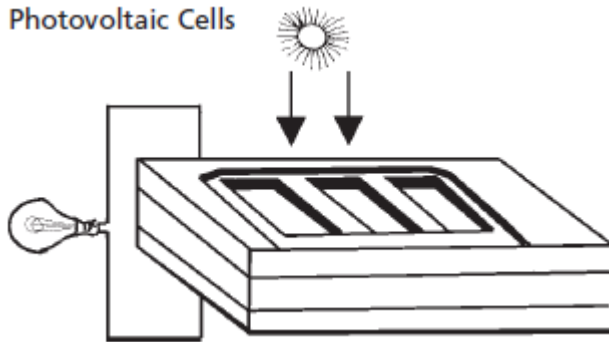

They work cleanly, safely and silently. They can be installed quickly in small modules, anywhere there is sunlight. Solar cells are made up of two separate layers of silicon, each of which contains an electric charge. When light hits the cells, the charges begin to move between the two layers and electricity is produced. PV cells are wired together to form a module. A module of about 40 cells is enough to power a light bulb. For more power, PV modules are wired together into an array. PV arrays can produce enough power to meet the electrical needs of a home. Over the past few years, extensive work has been done in decreasing PV technology costs, increasing efficiency, and extending cell lifetimes. Many new materials, such as amorphous silicon, are being tested to reduce costs and automate manufacturing.

PV cells are commonly used today in calculators and watches. They also provide power to satellites, electric lights, and small electrical appliances such as radios and for water pumping, highway lighting, weather stations, and other electrical systems located away from power lines. Some electric utility companies are building PV systems into their power supply networks.

PV cells are environmentally benign, ie. they do not release pollutants or toxic material to the air or water, there is no radioactive substance, and no catastrophic accidents. Some PV cells, however, do contain small quantities of toxic substances such as cadmium and these can be released to the environment in the event of a fire. Solar cells are made of silicon which, although the second most abundant element in the earth's crust, has to be mined. Mining creates environmental problems. PV systems also of course only work when the sun is shining, and thus need batteries to store the electricity.

CASE STUDIES

- In 1981, a plane called 'The Solar Challenger' flew from Paris to England in 5 hours, 20 minutes. It had 16,000 solar cells glued to the wings and tail of the plane and they produced enough power to drive a small electric motor and propeller. Since 1987, every three years there is a World Solar challenge for solar operated vehicles in Australia where the vehicles cover 3000 kms.
- The world's first solar-powered hospital is in Mali in Africa. Being situated at the edge of the Sahara desert, Mali receives a large amount of sunlight. Panels of solar cells supply the power needed to run vital equipment and keep medical supplies cool in refrigerators.
- Space technology required solar energy and the space race spurred the development of solar cells. Only sunlight can provide power for long periods of time for a space station or long distance spaceship.
- Japanese farmers are substituting PV operated insect killers for toxic pesticides.

- In recent years, the popularity of building integrated photovoltaics (BIPV's) has grown considerably. In this application, PV devices are designed as part of building materials (i.e. roofs and siding) both to produce electricity and reduce costs by replacing the costs of normal construction materials. There are more than 3,000 BIPV systems in Germany and Japan has a program that will build 70,000 BIPV buildings.

Solar thermal electric power: Solar radiation can produce high temperatures, which can generate electricity. Areas with low cloud levels of cover with little scattered radiation as in the desert are considered most suitable sites. According to a UNDP assessment, STE is about 20 years behind the wind energy market exploitation, but is expected to grow rapidly in the near future.

Mirror energy: During the 1980s, a major solar thermal electrical generation unit was built in California, containing 700 parabolic mirrors, each with 24 reflectors, 1.5 meters in diameter, which focused the sun's energy to produce steam to generate electricity.

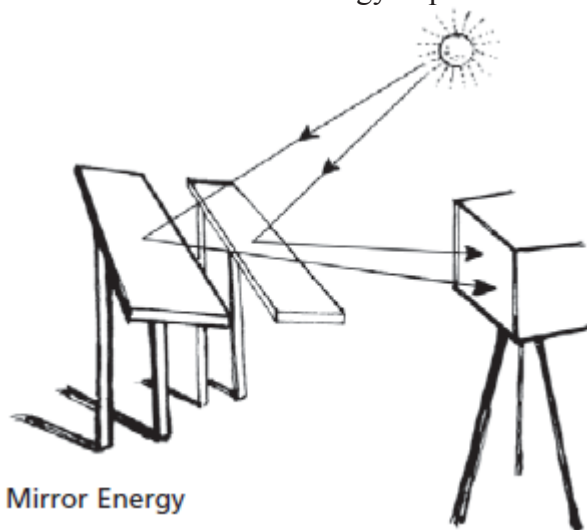

Solar thermal systems change sunlight into electricity, by focusing sunlight to boil water to make steam.

Biomass energy: When a log is burned we are using biomass energy. Because plants and trees depend on sunlight to grow, biomass energy is a form of stored solar energy. Although wood is the largest source of biomass energy, we also use agricultural waste, sugarcane wastes, and other farm byproducts to make energy.

There are three ways to use biomass. It can be burned to produce heat and electricity, changed to a gas-like fuel such as methane, or changed to a liquid fuel. Liquid fuels, also called biofuels, include two forms of alcohol: ethanol and methanol. Because biomass can be changed directly into liquid fuel, it could someday supply much of our transportation fuel needs for cars, trucks, buses, airplanes and trains with diesel fuel replaced by 'biodiesel' made from vegetable oils. In the United States, this fuel is now being produced from soybean oil. Researchers are also developing algae that produce oils, which can be converted to biodiesel and new ways have been found to produce ethanol from grasses, trees, bark, sawdust, paper, and farming wastes.

Organic municipal solid waste includes paper, food wastes, and other organic non-fossil-fuel derived materials such as textiles, natural rubber, and leather that are found in the waste of urban areas. Currently, in the US, approximately 31% of organic waste is recovered from

municipal solid waste via recycling and composting programs, 62% is deposited in landfills, and 7% is incinerated. Waste material can be converted into electricity by combustion boilers or steam turbines.

Note that like any fuel, biomass creates some pollutants, including carbon dioxide, when burned or converted into energy. In terms of air pollutants, biomass generate less relative to fossil fuels. Biomass is naturally low in sulphur and therefore, when burned, generates low sulphur dioxide emissions. However, if burned in the open air, some biomass feedstocks would emit relatively high levels of nitrous oxides (given the high nitrogen content of plant material), carbon monoxide, and particulates.

Biogas: Biogas is produced from plant material and animal waste, garbage, waste from households and some types of industrial wastes, such as fish processing, dairies, and sewage treatment plants. It is a mixture of gases which includes methane, carbon dioxide, hydrogen sulphide and water vapour. In this mixture, methane burns easily. With a ton of food waste, one can produce 85 Cu. M of biogas. Once used, the residue is used as an agricultural fertilizer

Denmark produces a large quantity of biogas from waste and produces 15,000 megawatts of electricity from 15 farmers' cooperatives. London has a plant which makes 30 megawatts of electricity a year from 420,000 tons of municipal waste which gives power to 50,000 families. In Germany, 25% of landfills for garbage produce power from biogas. Japan uses 85% of its waste and France about 50%.

Biogas plants have become increasingly popular in India in the rural sector. The biogas plants use cowdung, which is converted into a gas which is used as a fuel. It is also used for running dual fuel engines. The reduction in kitchen smoke by using biogas has reduced lung conditions in thousands of homes.

The fibrous waste of the sugar industry is the world's largest potential source of biomass energy. Ethanol produced from sugarcane molasses is a good automobile fuel and is now used in a third of the vehicles in Brazil.

The National Project on Biogas Development (NPBD), and Community/ Institutional Biogas Plant Program promote various biogas projects. By 1996 there were already 2.18 million families in India that used biogas. However China has 20 million households using biogas!

Activity 5:

What you may throw out in your garbage today could be used as fuel for someone else. Municipal solid waste has the potential to be a large energy source. Garbage is an inexpensive energy resource. Unlike most other energy resources, someone will collect garbage, deliver it to the power plant, and even pay to get rid of it. This helps cover the cost of turning garbage into energy. Garbage is also a unique resource because we all contribute to it.

Keep a record of all the garbage that you and our family produce in a day. What proportion of it is in the form of biomass? Weigh this.

How long would it take you to gather enough waste biomass to make a thankful (0.85 cu.m.) of biogas? (Remember one ton of biomass produces 85 cu.m. of biogas)

Wind Power: Wind was the earliest energy source used for transportation by sailing ships. Some 2000 years ago, windmills were developed

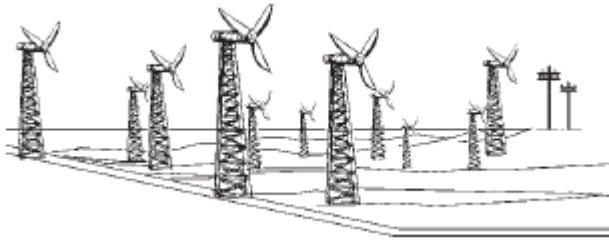

in China, Afghanistan and Persia to draw water for irrigation and grinding grain. Most of the early work on generating electricity from wind was carried out in Denmark, at the end of the last century. Today, Denmark and California have large wind turbine cooperatives which sell electricity to the government grid. In Tamil Nadu, there are large wind farms producing 850 megawatts of electricity. At present, India is the third largest wind energy producer in the world.

The power in wind is a function of the wind speed and therefore the average wind speed of an area is an important determinant of economically feasible power. Wind speed increases with height. At a given turbine site, the power available 30 meters above ground is typically 60 percent greater than at 10 meters.

Over the past two decades, a great deal of technical progress has been made in the design, siting, installation, operation, and maintenance of power-producing wind mills (turbines). These improvements have led to higher wind conversion efficiencies and lower electricity production costs.

Environmental Impacts: Wind power has few environmental impacts, as there are virtually no air or water emissions, or radiation, or solid waste production. The principal problems are bird kills, noise, effect on TV reception, and aesthetic objections to the sheer number of wind turbines that are required to meet electricity needs.

Although large areas of land are required for setting up wind farms, the amount used by the turbine bases, the foundations and the access roads is less than 1% of the total area covered by the wind farm. The rest of the area can also be used for agricultural purposes or for grazing.

Siting windmills offshore reduces their demand for land and visual impact.

Wind is an intermittent source and the intermittency of wind depends on the geographic distribution of wind. Wind therefore cannot be used as the sole resource for electricity, and requires some other backup or stand-by electricity source.

Tidal and Wave Power: The earth's surface is 70% water. By warming the water, the sun, creates ocean currents and wind that produces waves. It is estimated that the solar energy absorbed by the tropical oceans in a week could equal the entire oil reserves of the world – 1 trillion barrels of oil. The energy of waves in the sea that crash on the land of all the continents is estimated at 2 to 3 million megawatts of energy. From the 1970s several countries have been experimenting with technology to harness the kinetic energy of the ocean to generate electricity.

Tidal power is tapped by placing a barrage across an estuary and forcing the tidal flow to pass through turbines. In a one-way system the incoming tide is allowed to fill the basin through a sluice, and the water so collected is used to produce electricity during the low tide. In a two-way system power is generated from both the incoming as well as the outgoing tide.

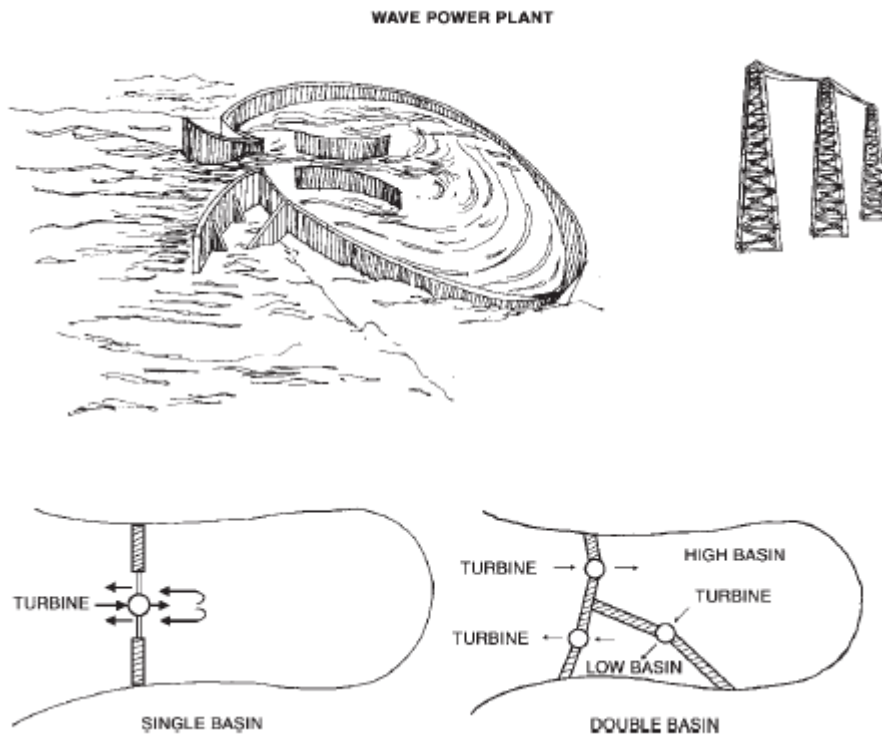

Tidal power stations bring about major ecological changes in the sensitive ecosystem of coastal regions and can destroy the habitats and nesting places of water birds and interfere with fisheries. A tidal power station at the mouth of a river blocks the flow of polluted water into the sea, thereby creating health and pollution hazards in the estuary. Other drawbacks include offshore energy devices posing navigational hazards. Residual drift current could affect spawning of some fish, whose larvae would be carried away from spawning grounds. They may also affect the migration patterns of surface swimming fish.

Wave power converts the motion of waves into electrical or mechanical energy. For this, an energy extraction device is used to drive turbogenerators. Electricity can be generated at sea and transmitted by cable to land. This energy source has yet to be fully explored. The largest concentration of potential wave energy on earth is located between latitudes 40 to 60 degrees in both the northern and southern hemispheres, where the winds blow most strongly.

Another developing concept harnesses energy due to the differences in temperature between the warm upper layers of the ocean and the cold deep sea water. These plants are known as Ocean Thermal Energy Conversion (OTEC). This is a high tech installation which may prove to be highly valuable in the future.

Geothermal energy: is the energy stored within the earth (“geo” for earth and “thermal” for heat). Geothermal energy starts with hot, molten rock (called magma) deep inside the earth which surfaces at some parts of the earth’s crust. The heat rising from the magma warms underground pools of water known as geothermal reservoirs. If there is an opening, hot

underground water comes to the surface and forms hot springs, or it may boil to form geysers. With modern technology, wells are drilled

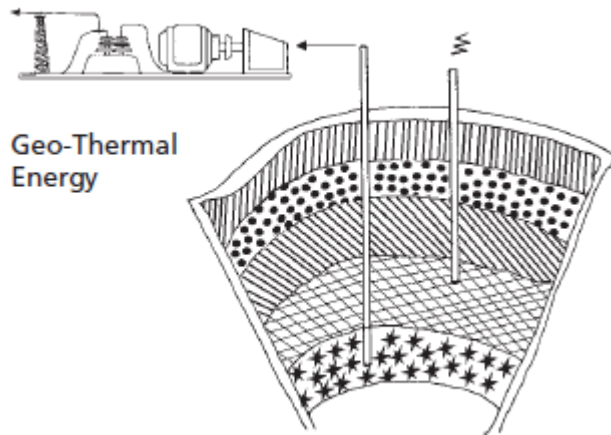

deep below the surface of the earth to tap into geothermal reservoirs. This is called direct use of geothermal energy, and it provides a steady stream of hot water that is pumped to the earth's surface.

In the 20th century geothermal energy has been harnessed on a large scale for space heating, industrial use and electricity production, especially in Iceland, Japan and New Zealand.

Geothermal energy is nearly as cheap as hydropower and will thus be increasingly utilised in future. However, water from geothermal reservoirs often contains minerals that are corrosive and polluting. Geothermal fluids are a problem which must be treated before disposal.

Nuclear Power

In 1938 two German scientists Otto Hahn and Fritz Strassman demonstrated nuclear fission. They found they could split the nucleus of a uranium atom by bombarding it with neutrons. As the nucleus split, some mass was converted to energy. The nuclear power industry however was born in the late 1950s. The first large-scale nuclear power plant in the world became operational in 1957 in Pennsylvania, US.

Dr. Homi Bhabha was the father of Nuclear Power development in India. The Bhabha Atomic Research Center in Mumbai studies and develops modern nuclear technology. India has 10 nuclear reactors at 5 nuclear power stations that produce 2% of India's electricity. These are located in Maharashtra (Tarapur), Rajasthan, Tamil Nadu, Uttar Pradesh and Gujrat. India has uranium from mines in Bihar. There are deposits of thorium in Kerala and Tamil Nadu.

The nuclear reactors use Uranium 235 to produce electricity. Energy released from 1kg of Uranium 235 is equivalent to that produced by burning 3,000 tons of coal. U235 is made into rods which are fitted into a nuclear reactor. The control rods absorb neutrons and thus adjust the fission which releases energy due to the chain reaction in a reactor unit. The heat energy produced in the reaction is used to heat water and produce steam, which drives turbines that produce electricity. The drawback is that the rods need to be changed periodically. This has impacts on the environment due to disposal of nuclear waste. The reaction releases very hot

waste water that damages aquatic ecosystems, even though it is cooled by a water system before it is released.

The disposal of nuclear waste is becoming an increasingly serious issue. The cost of Nuclear Power generation must include the high cost of disposal of its waste and the decommissioning of old plants. These have high economic as well as ecological costs that are not taken into account when developing new nuclear installations. For environmental reasons, Sweden has decided to become a Nuclear Free Country by 2010.

Although the conventional environmental impacts from nuclear power are negligible, what overshadows all the other types of energy sources is that an accident can be devastating and the effects last for long periods of time. While it does not pollute air or water routinely like oil or biomass, a single accident can kill thousands of people, make many others seriously ill, and destroy an area for decades by its radioactivity which leads to death, cancer and genetic deformities. Land, water, vegetation are destroyed for long periods of time. Management, storage and disposal of radioactive wastes resulting from nuclear power generation are the biggest expenses of the nuclear power industry. There have been nuclear accidents at Chernobyl in USSR and at the Three Mile Island in USA. The radioactivity unleashed by such an accident can affect mankind for generations.

Energy Conservation: Conventional energy sources have a variety of impacts on nature and human society.

India needs to rapidly move into a policy to reduce energy needs and use cleaner energy production technologies. A shift to alternate energy use and renewable energy sources that are used judiciously and equitably would bring about environmentally friendly and sustainable lifestyles. India must reduce its dependency on imported oil. At present we are under-utilizing our natural gas resources. We could develop thousands of mini dams to generate electricity. India wastes great amounts of electricity during transmission. Fuel wood plantations need to be enhanced and management through Joint Forestry Management (JFM) has a great promise for the future.

Energy efficient cooking stoves or 'chulas' help the movement of air through it so that the wood is burnt more efficiently. They also have a chimney to prevent air pollution and thus reduce respiratory problems. While over 2 lakh improved chulas have been introduced throughout the country, the number in active use is unknown as most rural people find it to be unusable for several reasons. TERI in 1995 estimated that in India 95% of rural people and 60% of urban poor still depend on firewood, cattle dung and crop residue for cooking and other domestic purposes. Biomass can be converted into biogas or liquid fuels ie. ethanol and methanol. Biogas digesters convert animal waste or agricultural residues into gas. This is 60% methane and 40% CO₂ generated by fermentation. The commonly used agri waste is dung of domestic animals and rice husk, coconut shells, straw or weeds. The material left after the gas is used acts as a fertilizer.

Small hydrogeneration units are environmentfriendly. They do not displace people, destroy forests or wildlife habitats or kill aquatic and terrestrial biodiversity. They can be placed in several hill streams, on canals or rivers. The generation depends on flowing water due to gravity. However, this fails if the flow is seasonal.

It is easy to waste energy but cheaper to save it than generate it. We can conserve energy by preventing or reducing waste of energy and by using resources more efficiently. People waste

energy because government subsidises it. If the real cost was levied, people would not be able to afford to waste it carelessly.

Industry and transport are the main growing users of energy in India. Industries that are known for generating pollution also waste the most energy. These include chemical industries, especially petrochemical units, iron and steel, textiles, paper, etc. Unplanned and inefficient public transport systems, especially in cities, waste large amount of energy. Using bicycles is an excellent method to reduce the use of energy. In agriculture, irrigation pumps to lift water are the most energy intensive agricultural use. These are either electrical or run on fossil fuels.

CASE STUDIES

Indian industries use more energy than necessary. Steel and energy: To produce one tonne of steel, India spends 9.5 million kilocalories. In Italy it is 4.3 million kilocalories and for Japan it is only 4.1 million kilocalories. Cement industry: Over 2 million kilocalories are used to produce one tonne of cement in India. In Germany it is 0.82 million kilocalories, in USA, 0.92 million kilocalories. Vehicles: Lighter materials should be used for cars. Instead of steel we should use aluminum, fiber glass or plastics. These lighter materials can reduce the weight by 15 % and increase the fuel economy by 6 to 8%. Refrigerators: Better technologies reduced the annual energy needed by a typical Danish 200 liter refrigerator (with no freezer) from 350 kilo Watt hour (kWh) to 90 kWh. Lighting: An 18-watt modern, compact fluorescent lamp, can replace a standard 75-watt incandescent lamp.

f) Land resources:

Land as a resource: Landforms such as hills, valleys, plains, river basins and wetlands include different resource generating areas that the people living in them depend on. Many traditional farming societies had ways of preserving areas from which they used resources. Eg. In the 'sacred groves' of the Western Ghats, requests to the spirit of the Grove for permission to cut a tree, or extract a resource, were accompanied by simple rituals. The outcome of a chance fall on one side or the other of a stonebalanced on a rock gave or withheld permission. The request could not be repeated for a specified period.

If land is utilized carefully it can be considered a renewable resource.

The roots of trees and grasses bind the soil. If forests are depleted, or grasslands overgrazed, the land becomes unproductive and wasteland is formed. Intensive irrigation leads to water logging and salination, on which crops cannot grow. Land is also converted into a non-renewable resource when highly toxic industrial and nuclear wastes are dumped on it.

Land on earth is as finite as any of our other natural resources. While mankind has learnt to adapt his lifestyle to various ecosystems world over, he cannot live comfortably for instance on polar ice caps, on under the sea, or in space in the foreseeable future.

Man needs land for building homes, cultivating food, maintaining pastures for domestic animals, developing industries to provide goods, and supporting the industry by creating towns and cities. Equally importantly, man needs to protect wilderness area in forests, grasslands, wetlands, mountains, coasts, etc. to protect our vitally valuable biodiversity.

Thus a rational use of land needs careful planning. One can develop most of these different types of land uses almost anywhere, but Protected Areas (National Park's and Wildlife

Sanctuaries) can only be situated where some of the natural ecosystems are still undisturbed. These Protected Areas are important aspects of good land use planning.

Land Degradation: Farmland is under threat due to more and more intense utilisation. Every year, between 5 to 7 million hectares of land worldwide is added to the existing degraded farmland. When soil is used more intensively by farming, it is eroded more rapidly by wind and rain. Over irrigating farmland leads to salinisation, as evaporation of water brings the salts to the surface of the soil on which crops cannot grow. Over irrigation also creates water logging of the topsoil so that crop roots are affected and the crop deteriorates. The use of more and more chemical fertilizers poisons the soil so that eventually the land becomes unproductive.

As urban centers grow and industrial expansion occurs, the agricultural land and forests shrink. This is a serious loss and has long term ill effects on human civilisation.

Soil erosion: The characteristics of natural ecosystems such as forests and grasslands depend on the type of soil. Soils of various types support a wide variety of crops. The misuse of an ecosystem leads to loss of valuable soil through erosion by the monsoon rains and, to a smaller extent, by wind. The roots of the trees in the forest hold the soil. Deforestation thus leads to rapid soil erosion. Soil is washed into streams and is transported into rivers and finally lost to the sea. The process is more evident in areas where deforestation has led to erosion on steep hill slopes as in the Himalayas and in the Western Ghats. These areas are called 'ecologically sensitive areas' or ESAs. To prevent the loss of millions of tons of valuable soil every year, it is essential to preserve what remains of our natural forest cover. It is equally important to reforest denuded areas. The linkage between the existence of forests and the presence of soil is greater than the forest's physical soil binding function alone.

CASE STUDY

Selenium – Punjab

In 1981-82, farmers from Hoshiarpur and Nawanshehar Districts approached scientists of the Punjab Agricultural University (PAU), Ludhiana, as wheat crops had turned white. Soil analysis indicated selenium (Se) levels in the area were above toxic limits. Se is a naturally occurring trace element, essential for animal and human health, but the gap between requirement and excess is narrow. Soils containing 0.5 microgrammes (ug) of Se per kg or more are injurious to health. In some areas of Punjab, Se levels range from 0.31 ug/kg to 4.55ug/kg. Rice cultivation requires the presence of standing water. Being highly soluble, Se dissolves and comes to the surface. The water then evaporates leaving the Se behind.

The soil is enriched by the leaf litter of the forest. This detritus is broken down by soil microorganisms, fungi, worms and insects, which help to recycle nutrients in the system. Further losses of our soil wealth will impoverish our country and reduce its capacity to grow enough food in future.

ROLE OF AN INDIVIDUAL IN CONSERVATION OF NATURAL RESOURCES

Until fairly recently mankind acted as if he could go on forever exploiting the ecosystems and natural resources such as soil, water, forests and grasslands on the Earth's surface and extracting minerals and fossil fuels from underground. But, in the last few decades, it has become increasingly evident that the global ecosystem has the capacity to sustain only a limited level of utilization. Biological systems cannot go on replenishing resources if they are overused or misused. At a critical point, increasing pressure destabilizes their natural balance.

Even biological resources traditionally classified as 'renewable' - such as those from our oceans, forests, grasslands and wetlands, are being degraded by overuse and may be permanently destroyed. And no natural resource is limitless. 'Non-renewable' resources will be rapidly exhausted if we continue to use them as intensively as at present.

The two most damaging factors leading to the current rapid depletion of all forms of natural resources are increasing 'consumerism' on the part of the affluent sections of society, and rapid population growth. Both factors are the results of choices we make as individuals. As individuals we need to decide;

- What will we leave to our children? (Are we thinking of short-term or long-term gain?)
- Is my material gain someone else's loss?

Greed for material goods has become a way of life for a majority of people in the developed world. Population growth and the resulting shortage of resources most severely affects people in the developing countries. In nations such as ours, which are both developing rapidly, and suffering from a population explosion, both factors are responsible for environmental degradation. We must ask ourselves if we have perhaps reached a critical flash point, at which economic 'development' affects the lives of people more adversely than the benefits it provides.

What can you do to save electricity?

- Turn off lights and fans as soon as you leave the room.
- Use tube lights and energy efficient bulbs that save energy rather than bulbs. A 40- watt tube light gives as much light as a 100 watt bulb.
- Keep the bulbs and tubes clean. Dust on tubes and bulbs decreases lighting levels by 20 to 30 percent.
- Switch off the television or radio as soon as the program of interest is over.
- A pressure cooker can save up to 75 percent of energy required for cooking. It is also faster.
- Keeping the vessel covered with a lid during cooking, helps to cook faster, thus saving energy.

EQUITABLE USE OF RESOURCES FOR SUSTAINABLE LIFESTYLES

Reduction of the unsustainable and unequal use of resources, and control of our population growth are essential for the survival of our nation and indeed of human kind everywhere. Our environment provides us with a variety of goods and services necessary for our day-to-day lives, but the soil, water, climate and solar energy which form the 'abiotic' support that we derive from nature, are in themselves not distributed evenly throughout the world or within countries. A new economic order at the global and at national levels must be based on the ability to distribute benefits of natural resources by sharing them more equally among the countries as well as among communities within countries such as our own. It is at the local level where people subsist by the sale of locally collected resources, that the disparity is greatest. 'Development' has not reached them and they are often unjustly accused of 'exploiting' natural resources. They must be adequately compensated for the removal of the sources to distant regions and thus develop a greater stake in protecting natural resources.

There are several principles that each of us can adopt to bring about sustainable lifestyles. This primarily comes from caring for our Mother Earth in all respects. A love and respect for Nature is the greatest sentiment that helps bring about a feeling for looking at how we use natural resources in a new and sensitive way. Think of the beauty of a wilderness, a natural

forest in all its magnificence, the expanse of a green grassland, the clean water of a lake that supports so much life, the crystal clear water of a hill stream, or the magnificent power of the oceans, and we cannot help but support the conservation of nature's wealth. If we respect this we cannot commit acts that will deplete our life supporting systems.

References:

1. Bharucha, E.; Kumar, S.; Nair, S.; and Foulger, S. "*Text book of Environmental Studies for Undergraduate Courses*" university press (India) Private Limited 3-6-747/1/A&3-6-754/1 Hyderabad 500029, Telangana, India ISBN: 978-81-7371-862-5